



DIESEL FUEL INJECTION SPARES

AN ISO 9001 : 2008 CERTIFIED COMPANY



Rajnish group of Industries started in 1976 from a small manufacturing unit which has now grown into a multi-divisional and multi-product entity claiming to be among the best quality manufacturers of Diesel Fuel Injection Spares. The success of the company is attributed to regular innovation, dedicated devotion towards product standardisation, dedication of staff and above all customer's satisfaction

Le Groupe Des Industries 'Rajnish' Fonde en 1976 comme une petite unite de fabrication est devenu maintenant une entite de mutiproduits et de multidivisions et se compte parmi les premiers fabricants des pieces detachees alimentees au Gas- oil de la meilleure qualite. On attribue le succes de la societe au personnel laborieux qui s'efforce toujours d'ameliorer les produits en apportant de nouveaux Changements et de donner la satisfaction aux clients. Les techniques tout a fait nouvelles de cad-cam



Ultra Modern Techniques of CAD-CAM have been employed to develop new components and designs as per customer's specifications. Apart from manufacturing a large no. of items, we are also trading some items to meet customer's demand.

Ont ete utilisees pour developper de nouveaux articles et modeles selon les besoins et caracteriques des clients. En plus de fabriquer un bon nombre d articles, nous faisons le commerce aussi de certains articles pour repondre aux besoins des clients.

The company enjoys substantial goodwill & brand equity and the product has deep penetration all along the length & width of country through a chain of dealer / distributor network. The product has also been appreciated by our customers in America Europe, Africa, Middle East & SE Asia.

La societe a une bonne reputation et ses produits et sa marque s'acceptent partout dans le pays a l'aide d'un grand reseau de negociants / distributeurs. Les produits ont ete apprecies par nos clients aux Etats - Units, Allemagne, Italie, Moyen - Orient et Singapore.

Our endeavour to act globally has encouraged us seeking your kind co-operation.

Notre effort de travailler globalement nous a encourage de demander votre collaboration aimable.

Best Regards

Salutations Cordiales

Rajnish Ahuja

Rahul Ahuja

Rajnish Ahuja

Rahul Ahuja

We thank you for your esteemed inquiry. Although extensive care has been taken while preparing this list, no guarantee of correctness or matching of part numbers & application can be taken. We would appreciate inquiries/orders in **Rajnish** part nos.

All O.E. Manufacturers names, numbers are used for reference purpose only & it does not imply that any part listed here is the product of these manufacturers.

Certificate

Standard **ISO / TS 16949:2009**
(3rd edition, 2009-06-15)

Certificate Registr. No. 01 111 1536754
IATF Certificate No. 0230405

Certificate Holder: **Rajnish Industries Pvt. Ltd.**
C-215, Phase -VIII, Focal Point,
Ludhiana - 141010, Punjab, India

Scope: Manufacturing of Pressure Die Cast, Sheet Metal, Plastic Moulded and CNC Steel Machined Components For Diesel Fuel Injection Pump

Proof has been furnished by means of an audit that the requirements of ISO / TS 16949:2009 are met.

Issue date/Expiry date: The certificate is valid 2023-08-14

Release date: 2021-08-14

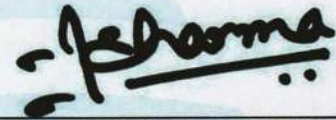

TÜV Rheinland Cert GmbH
Am Grauen Stein · 51105 Köln
Germany



2-IAO-QMC 01003

1 / 1

FEED PUMPS

00.1 001.000



Reference Part Nos.

Bosch	: 0 440 003 177	FP/KE 22 AD 240/2
Bosch	: 0 440 003 185	FP/KE 22 AD 247/2
Bosch	: 0 440 003 190	FP/KE 22 AD 223/2
Mico	: 9 440 030 001	FP/KE 22 AD 218/2
Bosch	: 0 440 003 178 (w/o H.P.)	FP/KE 22 AD 241/2
Bosch	: 0 440 003 180 (w/o H.P.)	FP/KE 22 AD 198/2
Mercedes Benz	: OM 360, 636 001 091 15 01, 001 091 73 01, 001 091 2701, 002 091 60 01	
Volvo	: 870 240	
Man	: 51 12101 7020, 51 12101 9020, 51 12101 7039(w/o H.P.)	
Man D	: 1648, 2148, 2840	
Iveco	: 0128 7476, 0128 7480, 0131 0021, 0 336 6125, 61653833, 718361, 755758, 760374, 8122111, 1287477(w/o H.P.)	
KHD (Deutz)	: 0128 7476, 0128 7480, 0152 17 213 10(w/o H.P.) 0152 17 213 20, 0336 6125, 336 6126(w/o H.P.), 812 2111, 0126 0836(w/o H.P.), 0128 7477 (w/o H.P.), 117 4843 (w/o H.P.), 812 2177(w/o H.P.), 128 7478 (w/o H.P.)	
Lancia	: 81 22111, 771333, 8122177 (w/o H.P.), 128 7478 (w/o H.P.)	
Magirus-Deutz	: 812 2111, 812 2177 (w/o H.P.)	

00.1 001.100 (1 001 P)



Reference Part Nos.

Bosch	: 0 440 008 007	FP/K 22 P 9
Bosch	: 0 440 008 998	FP/K 22 P 22
Bosch	: 0 440 008 015	FP/K 22 P 17
Bosch	: 0 440 008 029	FP/K 22 P 31
Bosch	: 0 440 008 037	FP/K 22 P 39
Bosch	: 0 440 008 045	FP/K 22 P 46
Bosch	: 0 440 008 048 (with prefilter assy.)	FP/K 22 P 51
Bosch	: 0 440 008 020	FP/K 22 P 22
Bosch	: 0 440 008 052 (without H.P.)	FP/K 22 P 58
Bosch	: 0 440 008 993 (without H.P.)	FP/K 22 P 58
Bosch	: 0 440 008 009 (without H.P.)	FP/K 22 P 11
Bosch	: 0 440 008 004 (with prefilter assy.)	FP/K 22 P 6
Mercedes-Benz	: 001 091 67 01, 000 090 05 50, 001 091 78 01, 002 091 70 01 (w/o H.P.) 000 090 24 50 (w/o H.P.), 000 090 70 50 (w/o H.P.)	
MAN	: 81 12101 6012, 51 12101 7083 (w/o H.P.), 51 121 7040 (w/o H.P.)	
Volvo	: 1699140, 244391, 240072 (with P/Assy), 243083, 7243083	
Scania	: 211005, 319789 (with prefilter assy.), 21105 (with P/assy.), 523260 (with P/assy.),	
Iveco	: 7981171 (w/o H.P.), 768702, 11737640, 9981532 (w/o H.P.) 772173 (without H.P.), 93163378 (w/o H.P.)	
Magirus Deutz	: 798 1171 (without H.P.), 998 1532 (w/o H.P.)	
KHD	: 076 8702, 117 3764, 1 203 8254. 414 0419 (w/o H.P.), 998 1532 (w/o H.P.) 1 203 4285(w/o H.P.)	

FEED PUMPS

00.1 002.000



Reference Part Nos.

Bosch	: 0 440 003 176	FP/KE 22 AD 112/2
Mico	: 9 440 030 002	FP/KE 22 AD 112/2
Bosch	: 0 440 003 182	FP/KE 22 AD 190/2
Bosch	: 0 440 003 184	FP/KE 22 AD 246/2
Bosch	: 0 440 003 223	FP/KE 22 AD 283/2
Bosch	: 0 440 003 228	FP/KE 22 AD 290
Bosch	: 0 440 003 186 (Al. Bowl)	FP/KE 22 AD 254/2
Bosch	: 0 440 003 183 (Without H.P.)	FP/KE 22 AD 243/2
Bosch	: 0 440 003 213 (Thread 1/4-18 NPTF)	FP/KE 22 AD 266/2
Bosch	: 0 440 003 232 (Al. Bowl, Thread 1/2 - 20 UNF)	FP/KE 22 AD 299
Bosch	: 0 440 003 199	FP/KE 22 AD 249/2
Bosch	: 0 440 003 212	FP/KE 22 AD 265/2
Bosch	: 0 440 003 233	FP/KE 22 AD 301/2

MERCEDES-BENZ	: OM 352, 911 B , 001 091 11 01, 001 091 63 01, 001 091 14 01 (Al. Bowl)
MAN	: 51 12101 7007, 51 12101 7024, 51 12101 7006 (Al. Bowl)
MAN	: 90 80111 2133, 90 80111 2141, 51 12101 7035 (w/o H.P.)

00.1 002.100 (1 002 P)



Reference Part Nos.

Bosch	: 0 440 008 003	
Bosch	: 0 440 008 999	FP/K 22 P5
Bosch	: 0 440 008 014	FP/K 22 P5
Bosch	: 0 440 008 035	
Bosch	: 0 440 008 046	
Bosch	: 0 440 008 017 (without H.P.)	FP/KE 22 P18
Bosch	: 0 440 008 013 (Thread 1/4 - 18 NPTF)	FP/K 22 P15
Bosch	: 0 440 008 040 (Thread 1/2 - 20 UNF)	FP/K 22 P42

Mercedes Benz	: OM 355, 346, 3638 001 091 61 01, 001 091 25 01, 000 090 03 50
MAN	: 90 80111 2114, 81 12101 6022, 51 1201 7089 (Thread 1/4 -18 NPTF)
Iveco	: 769696, 93159106
KHD	: 128 7495, 126 1133, 126 0836, 126 2033

FEED PUMPS

00.1 002.200 (1 002 L)



Reference Part Nos.

Bosch	: 0 440 008 027	FP/K 22 P29
Bosch	: 0 440 008 994	FP/K 22 P44
Bosch	: 0 440 008 997	FP/K 22 P29
Bosch	: 0 440 008 043	FP/K 22 P44

Mercedes-Benz	: OM-402 / OM-403, 1619
	: 001 091 84 01, 000 090 21 50, 000 090 06 50, 002 091 49 01
Kassbohrer	: 8 312 000 572
Liebherr	: 500 27 16

00.1 002.400



Reference Part Nos.

Bosch	: 0 440 003 183	FP/KE 22 AD 243/2
Bosch	: 0 440 003 229	FP/KE 22 AD 291/2

MAN	: 51 12101 7035, 51 12101 7034
Renault	: 50 01 000 043, 50 00 242 581
Saviem	: 50 01 000 043, 50 00 242 581

FEED PUMPS

00.1 003.000



Reference Part Nos.

Bosch	: 0 440 004 018	FP/KS 22 AD 6
Mico	: 9 440 030 003	FP/KS 22 AD 5
Bosch	: 0 440 004 017	FP/KS 22 AD 5
	(without H.P.)	
Bosch	: 0 440 030 003	FP/KS 22 AD 45/2
Bosch	: 0 440 004 019	FP/KS 22 AD 6/3
Bosch	: 0 440 004 020	FP/KS 22 AD 6/4
Bosch	: 0 440 004 027	FP/KS 22 AD 15
Bosch	: 0 440 004 028	FP/KS 22 AD 16
Bosch	: 0 440 004 032	FP/KS 22 AD 15/3
Bosch	: 0 440 004 033	FP/KS 22 AD 25/4
Bosch	: 0 440 004 043	FP/KS AD 6/2
Mefin	: 0 840 004 002	

Mercedes Benz	: 2628	000 091 84 01, 000 091 83 01 (w/o H.P.), 001 091 04 01, 000 091 00 01, 000 091 85 01, 001 091 12 01
Massey Ferguson-Hanomag	: 2868 360 M1, 2868 360 M1	
Romania	: For U650 Tractor	
New Holland (Fiat Geotech.)	: 9959826	
Volvo	: 241380 P3/P4	
Iveco	: 0076 0428, 0128 7485, 0128 7489, 0355 0549, 0812 2184, 764954, 9018634, 9928977, 9959826,	
MAN	: 51 12101 7009	
KHD	: 812 2184, 1215 2597, 128 7485, 128 7489	
KHD (Deutz)	: FL 814, BFL 913	

00.1 003.100 (1 003 P)



Reference Part Nos.

BOSCH	: 0 440 004 019	FP/KS 22 AD 6/3
FIAT	: 760428, 8122184	
KHD	: 812 2184	
LANCIA	: 760428, 8122184	
MAGIRUS-DEUTZ	: 812 2184	
MAN	: 51 12101 7009	

FEED PUMPS

00.1 004.000



00.1 035.000



Application
Deutz 912

00.1 067.000



Reference Part Nos.
BOSCH : 0 440 004 067

FEED PUMPS

00.1 007.000



M 14 x1.5
internal thread

Ref. Part Nos. :
Bosch:0 440 011 007
FP/AH3/7
Merc. : 000 091 2190
MAN : 51 12150 7006,
51 12150 6011
Iveco : 240 8351

00.1 007.100



M 14 x1.5
internal thread

00.1 007.200



M 16 x1.5
external thread

M 14 x1.5
internal thread

Reference Part Nos.
Bosch : 0 440 011 002

00.1 007.300



M 14 x1.5
internal thread

M16 x1.5
external thread

00.1 007.600



M14 x1.5
Internal thread

M16 x1.5
External thread

00.1 008.000



M14 x1.5
internal thread

Cast Iron

00.1 008.100



M14 x1.5
internal thread

Cast Iron

00.1 008.200



M16 x1.5
external thread

00.1 009.000



M14 x1.5
internal thread

Ref. Part Nos. : 0 440 011 007
with Cast Iron Body

FEED PUMPS

00.1 011.000



Reference Part Nos.

Bosch	:	0 440 004 040	FP/KS 22 AD 23/2
Mico	:	9 440 030 011	FP/KS 22 AD 48/2
Bosch	:	0 440 004 030	FP/KS 22 AD 22
Bosch	:	0 440 004 031	FP/KS 22 AD 23
Bosch	:	0 440 004 059	FP/KS 22 AD 39/2
Bosch	:	0 440 004 054	FP/KS 22 AD 37/2
Bosch	:	0 440 004 066	FP/KS 22 AD 47

Mercedes Benz	:	OM 314, 608 001 091 26 01, 352 070 05 03
MAN	:	51 12101 7019
MAN D	:	2156, 2358
IVECO	:	0 128 7487, 0 336 3174, 0 900 0808, 8122185, 7736300, 9000808
KHD	:	FL 812, B 0150 17 15 10, 128 7487, 336 3174, 812 2185, 129 9362
Magirus-Deutz	:	812 2185, 001 091 26 01, 352 070 0503
Fiat	:	763150, 9 000808, 81 221 85, 75204059, 711 0925
Lancia	:	763150, 9000808, 8122185, 75204059, 7110925
MWM Diesel	:	6 0520 20 0 0032, 9 0520 20 0 0002
Saurer	:	154 0843
Unic	:	009 000 808
Bomag	:	057 163 65

00.1 013.000



Reference Part Nos.

F802-A50-028

FEED PUMPS

00.1 017.000



Reference Part Nos.

Bosch : 0 440 017 011
 Bosch : 0 440 017 996

Application

Mercedes Benz : **OM 366**
 000 090 22 50, 002 091 61 01
 Iveco : 93163579
 Fiat Iveco : 42484481, 79046324, 9959385
 Magirus Deutz : 93163579

00.1 018.000



Reference Part Nos.

Mico : 9 440 030 018 FP/KS 22 AD 55/2
 9 440 037 000

Application HMT Zetor 2511

00.1 019.000



Reference Part Nos.

Bosch: 0 440 007 998
 Bosch: 0 440 007 017

00.1 028.000



Reference Part Nos.

Mico : 9 440 030 028 FP/KE 22 AD 310.
 Bosch : 0 440 003 240 (H.P. 3 020) FP/KEG 22 AD 112/2.
 Bosch : 0 440 003 247 (H.P. 3 005) FP/KEG 22 AD 283/2.
 Bosch : 0 440 003 998.
 Bosch : 0 440 003 996.

Mercedes : 000 090 64 50, 000 090 10 50, 000 090 27 50.
 Volvo : 12705196.
 Iveco : 93190295.
 KHD : 128 8172, 128 7474.
 DAF : 245339, 1287765, 248252.
 Fiat Allis : 75203551.
 Case : E 067220.

FEED PUMPS

00.1 029.000



Reference Part Nos.

BOSCH	: 0 440 003 238	FP/KEG 22AD 240/2
BOSCH	: 0 440 003 245 (w/o H.P.)	FP/KEG 22AD 198/2
BOSCH	: 0 440 003 239 (w/o H.P.)	FP/KEG 22AD 241/2

Mercedes Benz	: OM 360	
		003 091 48 01 (w/o H.P.)
MAN	: 51 12101 7039 (w/o H.P.)	
Iveco	: 93190254, 81 98298 (w/o H.P.)	
KHD	: 117 4845, 117 4843 (w/o H.P.)	
Magirus-Deutz	: 9319 0254	
Renault	: 50 00 823 465 (w/o H.P.)	
Bomag	: 057 163 63, 057 163 68 (w/o H.P.)	

00.1 030.000



Reference Part Nos.

MICO	: 9 440 030 030	FP/KSG 22 AD 45/2
------	-----------------	-------------------

Application

MAN D 0022 M. Savlem.

00.1 031.000



Reference Part Nos.

Mico.	: 9 440 030 031	FP/KEG 22 AD 281/2.
Bosch	: 0 440 004 071	FP/KSG 22 AD 23/2.
Bosch	: 0 440 004 996	FP/KS 22 AD 23/2.

Merc.	: OM 314 , 003 091 72 01, 000 090 04 50, 000 090 11 50.	
-------	---	--

Iveco	: 931 90098.	
KHD	: 336 3174.	
Magirus-Deutz	: 9319 00 98.	
MWM-Diesel	: 9 0520 20 0 0032.	
Fiat-Allis	: 752 04059	
Yanmar	: BTD. 22. 52011.	
TATA	: TATA 207, TATA GATI	

FEED PUMPS

00.1 044.000



Ref. Part No : 51121500001
51121500002

Application : MAN

00.1 045.000



Ref. No : 5010412930

00.1 048.000



Ref. Part No : 1332609

Application : DAF

00.1 049.000



Reference Org. Part Nos.

Merc. : 000 090 7350

00.1 050.000

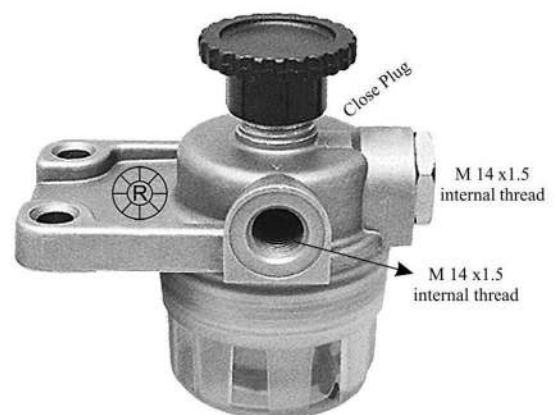

Reference Org. Part Nos.

Merc. : 000 090 6050

FEED PUMPS

00.1 043.000



Reference Part Nos.

Bosch : 0 440 017 043 FP/KG 24 MW 303

Bosch : 0 440 017 990

Merc. : 000 090 7450

Sliding Tappet : A Type (00.2060.000 + 00.2026.026)

00.1 068.000



Reference Part Nos.

Bosch : 0 440 008 068

Pin - 024,11.5 mm

FP/KG 24 P 200

Application

KHD : 418 8108

Volvo : 244825

Iveco : 71445067, 8092471

00.1 069.000

Reference Part Nos.

Bosch : 0 440 008 069

Pin - 028,13.5 mm



00.1 070.000



Reference Part Nos. : 0440 008 070

Pin - 028,13.50 mm

Thread : M 14 X 1.50

00.1 071.000



Reference Part Nos. :

Pin - 024,11.5 mm

Thread : M 14 X 1.50

FEED PUMPS

00.1 072.000



Reference Part Nos.

0440 008 072
Pin - 024,11.5 mm
Thread : M 14 X 1.50

00.1 073.000



Reference Part Nos.

Bosch : 0 440 008 073
Pin - 028,13.5 mm
Thread : M 14 X 1.50

00.1 074.000



Reference Part Nos.

Bosch : 0 440 008 074 FP/KG 24 P 303
Pin - 028,13.5 mm

Application

Merc. : 003 091 06 01
MAN : 51 12101 7097

00.1 076.000



Reference Part Nos.

Bosch : 0 440 008 076 FP/KG 24 P 202
Pin - 024,11.5 mm

Application

Merc. : 003 091 42 01.
KHD : 4184575.
MAN : 51 12101 7067.
Iveco : 93160462, 76026140
Magirus-Deutz : 9316 0462

00.1 084.000



Reference Part Nos.

Bosch : 0 440 008 084 FP/KG 24 P 304
Pin - 028,13.5 mm

Application

MAN : 51 12101 7081
51 12101 7106

00.1 086.000



Reference Part Nos.

Bosch : 0 440 008 086 FP/KG 24 P 305
Pin - 028,13.5 mm

Thread : 1/4" x 18 NPTF Inlet & Outlet

FEED PUMPS

00.1 089.000



Reference Part Nos.

Bosch : 0 440 008 089 FP KG 24 P 307
Pin - 028,13.5 mm

Application

Volvo : 863474
MAN : 51 12101 7121
DAF : 1339 048
Scania : 1307770

00.1 092.000



Application

MAN: 51 12101 7075
51 12101 7107

Reference Part Nos.

Bosch : 0 440 008 092
FP/KG 24 P 210
Pin - 024,11.5 mm

00.1095.251



Application

0440 003 251 FP / KEG 24AB 500
0440 003 254 FP / KEG 24AB 504
0440 003 256 FP / KEG 24AB 505

00.2060.000 + 00.2026.026
Sliding Tappet A Type

00.1 094.000



Application Renault
Sliding Tappet A Type
00.2060.000 + 00.2026.026

00.1093.000



Ref. no. : 0 440 017 030
Height from flange

00.1 108.000



Reference Part Nos.
Bosch : 0 440 008 108

FEED PUMPS

00.1 113.000



Application

Scania : 1422627

Reference Part Nos.

Bosch : 0 440 008 113 FP/KG 24 P 314

Pin - 028,13.5 mm

00.1134.000



Application

Bosch : 0 440 008 134 FP / KG 24P 221

Pin - 024,11.5 mm

00.1137.000



Reference Part Nos.

0 440 008 137

Thread : M14 X 1.5 ON INLET

Pin : 028, 13.50mm

With HP on Left Side

00.1173.000



Reference Part Nos.

0 440 008 173

Thread : M14 X1.50

Pin 028,13.5mm

00.1 249.000



Reference Part Nos. :

Bosch : 0 440 003 249

Thread : M 14 X 1.50

Sliding Tappet : A- Type

00.2060.000 + 00.2026.026

00.1 986.000



Reference Part Nos.

Bosch : 0 440 008 986 FP/KG 24 P 203

Pin 024,11.5mm

Application Merc. : 000 090 35 50

00.1 989.000



Reference Part Nos.

Bosch : 0 440 008 989 FP/KG 24 P 303

Pin 028,13.5mm

Application

Merc. : OM 442

000 090 31 50

FEED PUMPS

00.1 100.000

Reference Part Nos.
Caterpillar : 4W0788
OEM : 1052508 4W07788



00.1 101.000

OEM : E320C



00.1 102.000



00.1 120.000



Reference Part Nos.
V2H001M1

00.1 120.111



Reference Part Nos.
V2 HFM 01A
46 408 760

00.1 121.000



Reference Part Nos.
Motorpal : V2 HFM 01AA
V2 HFM 51AA

00.1108.200



Reference Part Nos :
Bosch : 0 440 008 009

00.1 121.110



00.1 122.000



Reference Part Nos.
Motorpal : CD1M 2291

FEED PUMPS

00.1 123.000



Reference Part Nos.
Motorpal : CD1M 2292

00.1 125.000



Reference Part Nos.
V2H001M1-T

00.1 130.000



Reference Part Nos.
Motorpal CD2M 2293
Application
Motorpal

00.1 135.000



Reference Part Nos.
Motorpal CRI-2265
Application
Motorpal

00.1 170.000



Application
Renault

FEED PUMP 4 VALVE

00.1 005.100



Roller Dia : 17.00
 Roller Thickness : 6.50
 Height from flange to top
 of Roller : 28.75
 Collar Dia (I) 30.85
 (II) 31.85
 Height of Collar - 13.00

Reference Part Nos.

Bosch	: 0 440 008 005	FP/KD 22 P8
Bosch	: 0 440 008 028	FP/KD 22 P30
Bosch	: 0 440 008 031	FP/KD 22 P33
Bosch	: 0 440 008 039	FP/KD 22 P41
Bosch	: 0 440 008 053	FP/KD 22 P59
Bosch	: 0 440 008 118	FP/KD 22 P91
Bosch	: 0 440 008 996	FP/KD 22 P8
Bosch	: 0 440 008 030	FP/KD 22 P32 (1/4 18 NPTE)
Zexel	: 105237 - 4180	
	: 105237 - 1100	E 120 V/O
	With Optional Banjo Bolt 01. 5614.160, 01.5614.150	

Application

ISUZU	: 6RB1/E120/CXZ
NISSAN	: RF8/EG8/RH8/JO8C
MAN	: 81 96 410 0661, 81 96410 0650, 51 12101 7056, 51 12101 7043
Mercedes	: 000 090 14 50, 001 091 95 01
MCC	: 000 8283 V000
Dresser	: 684 697 C91
IH	: 684 697 C91
KHD	: 126 1834, 1202 8248, 117 4520, 0171 17 26 10, 126 0837, 1203 8320

00.1 005.200 (L)



Reference Part Nos.

Zexel : 105237 - 1341

Application

HINO:6D22/6D40/8DC9/BU

Roller Dia : 17.00
 Roller Thickness : 6.50
 Height from flange to top
 of Roller : 28.75
 Collar Dia (I) 30.85
 (II) 31.85
 Height of Collar - 13.00

00.1 995.100

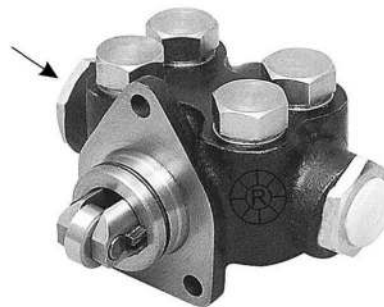

Roller Dia : 17.00
 Roller Thickness : 6.50
 Height from flange to top
 of Roller : 28.75
 Collar Dia (I) 30.85
 (II) 31.85
 Height of Collar - 13.00

Reference Part Nos.

Bosch	: 0 440 008 077	FP/KD 22 P80
Bosch	: 0 440 008 090	FP/KD 22 P80-1
Bosch	: 0 440 008 114	FP/KD 22 P89
Bosch	: 0 440 008 116	FP/KD 22 P90
Bosch	: 0 440 008 995	FP/KD 22 P10
Bosch	: 0 440 008 097	FP/KD 22 P85 (1/4 - 18 NPTE)
MAN	: 51 12101 7071	
Mercedes	: 003 091 1401, 000 090 1550	
KHD	: 1218 7781, 131 9286	
MWM Diesel	: 6 0520 20 3 0033	
Renault	: 50 00 288 129 (Thread 1/4 - 18 NPTE)	
Scania	: 1123841	
Iveco	: 93193277	
MTU	: 003 091 43 01	

FEED PUMP 4 VALVE

00.1 900.100



Reference Part Nos. ND : 092100-1900

(Long Connector & Brass filter bottom sealed are Optional)

Roller Dia 17.00

Roller Thickness : 6.50

Height from flange to top of Roller: 28.75

Collar Dia (I) 30.85

(II) 31.85

Height of Collar- 13.00

00.1901.000



Reference Part Nos.: 092100-2610

Roller Dia: 15.00

Roller Thickness : 8.80

Height from flange to top of Roller : 22.65

Collar Dia (I) 30.85

(II) 31.85

Height of Collar: 9.80

00.1 901.100



Reference Part Nos. : 092100 - 3161

Application

HINO : J08C/J08E/LOHAN

Roller Dia : 15.00

Roller Thickness : 6.50

Height from flange to top of Roller: 22.65

Collar Dia (I) 30.85

(II) 31.85

Height of Collar - 9.00

00.1 901.200



Reference Part Nos. : 105230 - 1111

Application

ISUZU: NKR71T/HURO 2

Roller Dia : 15.00

Roller Thickness : 6.50

Height from flange to top of Roller: 22.80

Collar Dia (I) 30.85

(II) 31.85

Height of Collar - 9.00

FEED PUMPS 4 VALVE

00.1 906.100

Reference Part Nos.

BOSCH : 0 440 008 071 FP / KD / 22 P78

Application : Scania 123



Roller Dia : 24.00
Roller Thickness : 5.50
Height from flange to top of Roller : 32.00

Collar Dia : (I) 30.40
(II) 31.40
Collar Height : 15.50

00.1 908.200

REF. NO. 105237 4890

9 440 610 193

NP-FP/KD-HD



Roller Dia : 22.00
Roller Thickness : 6.30
Height from flange to top of Roller : 29.00
Height after compression : 20.90

Collar Dia : (I) 30.60
(II) 31.00

Collar Height : 11.00

Thickness of Tappet : 15.00

Height of Tappet Body from flange : 24.00

APPLICATION : MITSUBISHI

00.1907.100

REF. NO. 105237-5460



Roller Dia : 20.00
Roller Thickness : 6.30
Height from flange to top of Roller (Before Compression) : 25.50
Height after compression : 16.75

Collar Dia : (I) 30.85
(II) 31.65

Collar Height : 11.00

Thickness of Tappet : 14.90

Height of Tappet Body from flange : 23.00

00.1 909.100



Roller Dia : 24.00
Roller Thickness : 5.50
Height from flange to top of Roller : 32.50
Collar Dia : (I) 30.00
(II) 31.85
Collar Height : 14.50

Application :
SP/KE: 2205.5
CHINESE TRUCK

00.1 908.100

Reference Part Nos.

105237-4410

Application : Hino F 20



Roller Dia : 22.00
Roller Thickness : 6.30
Height from flange to top of Roller : 29.00
Height after compression : 20.60

Collar Dia : (I) 30.85
(II) 31.85
Collar Height : 11.00

00.1 910.000

Reference Part Nos. :

105237-6020



Pin Dia : 10.00
Height from flange to top of Pin : 33.25
Collar Dia : 31.85
Collar Height : 7.00

FEED PUMPS 4 VALVE

00.1911.200



Ref Org No.: 105237-6130

Roller Dia : 10.00
 Height from flange to top of roller : 25.00
 Collar Dia : 38.00
 Collar Height : 7.00

00.1 022.100



Roller Dia : 17.00
 6.50
 1 to top

Collar Dia : 30.45
 Collar Height : 3.00

ReferencePart Nos.

- Bosch : 0 440 008 022 FP/KD 22-P24
 (with Alumn Bowl)
- Bosch : 0 440 008 059 FP/KD 22-PS2-1
- KHD : 067073900261132
- Scania : 347102
- Steyr : 85 60 08 0036

00.1036.000



**Ref.: MTZ-80
 App: BELARUS**

00.1058.111



- Roller Dia :-15.00
- Roller Thickness:-5.00
- Collar Height :- 12.50
- Height From Flange to Top of Roller:-24.00
- Compression Height:-12.00
- Collar Dia (I):-30.85
 (II):-31.85
- Width of Tappet Body:- 11.00

FEED PUMPS

00.1 006.000



Reference Part Nos.

	FP/K 22BC 47
BOSCH : 0 440 001 007	FP/K 22BC 47/2
BOSCH : 0 440 001 0022	FP/K22 BC 135
MERCEDES BENZ	: 000 091 65 01
MAN	:11 21508 0002
VOLVO	:238222, 77988
SCANIA	:210787
IVECO	:9922392
KHD	:128 7462,812 2245,128 7463
RENAULT	:00 25 838 017.00 03 020 500
	08 54 310 800
FIAT	:9922392
LANCIA	:9922392
MWM-DIESEL	:6 0520 20 4 0003
HANOMAG(RHEINSTAHLAG)	:197 942 706,506 686 000
HENSCHEL	:580 424 00 00
BERLIET	:30 20 500

00.1016.000



Reference Part Nos.

American Bosch	: SPA 22 A 18
American Bosch	: SPA 22 B 18
American Bosch	: SPA 22 B 19

MACK(USA)919GG
Thread 1/4" 18NPTF (Intel & Outlet)

FEED PUMPS

00.1 051.000



Reference Part Nos.

Zexel	:	105210-1800	
Zexel	:	105210-4250	
Zexel	:	105210-4251	
Zexel	:	105210-4280	FP/KE-A
Zexel	:	105210-1980	
Zexel	:	105210-4931	
Zexel	:	105210-4261	
Zexel	:	105210-5510 (with Banjo Bolt)	
Zexel	:	105210-1140	

Application

HINO : H07C/6D22/DA120
 Isuzu DA 120/DH 100
 Komatsu 6 D 105
 Toyota 3B/13B
 EL 100 6 D 22
 Mitsubishi : 8DC/40, 8DC/60, 6D/20/22
 Fuso : 8DC 40/60

00.1 051.100



Reference Part Nos.

Zexel	:	105217-4000
Zexel	:	105217-1580 FP/KE-P
Zexel	:	105217-1730
Zexel	:	105217-1480
Zexel	:	105207-1200

Application

ISUZU : BDC9/RE/RD8/EK100
 Hino EK 100
 Nissan RD6/RD8
 Mitsubishi: 8DC8/8DC9

00.1 051.200



Reference Part Nos.

Zexel	:	092100-0402	ND-FP/KE-22 AC
Zexel	:	092100-0971	
Zexel	:	105210-4630	
Denso	:	092100-2650	

Application

Toyota : **2F/H/J/NKR66**
 Toyota : 2J/ Toyota 2H

FEED PUMPS

00.1 052.000



Reference Part Nos.

Zexel : 105220-1720
 Zexel : 105220-1871
 Zexel : 105220-1860
 Zexel : 105220-1800
 Zexel : 105220-1880
 Zexel : 105220-5001
 Denso : 092100-0372

Application

Hino / Canter
 Nissan SD 22/SD 23
 Mitsubishi 4D30/4D31/4D32/PS100
 Komatsu 6 D 95 L
 Daihatsu Engine B/3B 13B/DG

00.1 052.200



Reference Part Nos.

Zexel : 105220-1570
 Zexel : 105220-1590
 Zexel : 105220-1591
 Zexel : 105220-5251
 Zexel : 105220-4742
 Zexel : 105220-1070
 Zexel : 105220-4561
 NP-FP/KS 22 AC
 Zexel : 105220-4781
 Denso : 092100-1200

Application

Isuzu C 190/C240/6BDI
 Isuzu D 500
 Isuzu 6 BB1 PD,
 Isuzu 6 BB1 LK,
 Isuzu 6 BB1 LF,
 Hitachi
 Bedford

00.1 052.400



Collar Hight : 13

Reference Part No. 105237-6593 (2NP)
 Mitsubishi : **PS125/TURBO/CANTER**

00.1062.400



Reference Part Nos. : 105273-6593

Roller Dia : 15.00
 Roller Thickness : 8.80
 Height from flange to top
 of Roller : 22.00
 Collar Dia : (I) 30.85
 (II) 31.85
 Collar Height : 11.00

FEED PUMPS

00.1 053.000



Reference Part No.

Zexel : 105220 7060
Zexel : 105220 7180

Pin Dia : 10.00
Height from flange to top
of Pin : 20.80
Collar Dia : 31.85
Collar Height : 7.00

Application

NISSAN : PE6/BU

00.1 053.200



Reference Part No.

ZEXEL : 105220 - 7010

Pin Dia : 10.00
Height from flange to top
of Pin : 20.80
Collar Dia : 31.85
Collar Height : 7.00

Application

NISSAN : PF6/BU(PIN TYPE)

00.1 054.000



Roller Dia : 15.00
Roller Thickness : 8.80
Height from flange to top
of Roller : 22.00
Collar Dia : (I) 30.85
(II) 31.85
Collar Height : 8.00

Reference Part Nos.

ND : 092100 0942 ND-FP/KE22A CND 094
092100 1490
ZEXEL : 105210 1941
ZEXEL : 105210 1351
ZEXEL : 105210 4151

Application

Mitsubishi : PS190/FM516/6D22

00.1 054.400



Reference Part Nos. : 092100 - 3370

Roller Dia : 15.00
Roller Thickness : 8.80
Height from flange to top
of Roller : 22.00
Collar Dia : (I) 30.85
(II) 31.85
Collar Height : 8.00

Application

Toyota : 130HT/140HT

00.1 055.000



Reference Part Nos.

ZEXEL : 105220-5690

Roller Dia : 15.00
Roller Thickness : 8.80
Height from flange to top
of Roller : 22.00
Collar Dia : (I) 30.85
(II) 31.85
Collar Height : 8.00

Application

NISSAN : BTX/BU

00.1 055.200



Roller Dia : 15.00
Roller Thickness : 8.80
Height from flange to top
of Roller : 22.00
Collar Dia : (I) 30.85
(II) 31.85
Collar Height : 8.00

FEED PUMPS

00.1 055.400 (Old No. 00.1 061.400)



Reference Part Nos. :
092100 - 2840

Roller Dia : 15.00
Roller Thickness : 8.80
Height from flange to top
of Roller : 22.00
Collar Dia : (I) 30.85
(II) 31.85
Collar Height : 8.00

00.1 056.000



Reference Part Nos. :
ZEXEL :105207-1041

Roller Dia : 17.00
Roller Thickness : 6.50
Height from flange to top
of Roller : 29.25
Collar Dia : (I) 30.85
(II) 31.85
Collar Height : 13.00

00.1 057.200



Reference Part Nos. :
ZEXEL : 105210-6370

Pin Dia : 10.00
Collar Dia : 31.85
Collar Height : 7.00

Height from flange to top
of Pin : 20.75

Application
ISUZU: NKR 71(PIN)

00.1 058.000



Roller Dia : 15.00
Roller Thickness : 8.80
Height from flange to top
of Roller : 24.15
Collar Dia : (I) 30.85
(II) 31.85
Collar Height : 12.50

00.1 059.000



Roller Dia : 15.00
Roller Thickness : 8.80
Height from flange to top
of Roller : 32.00
Collar Dia : (I) 30.85
(II) 31.85
Collar Height : 20.00

00.1 060.000



Roller Dia : 15.00
Roller Thickness : 8.80
Height from flange to top
of Roller : 22.40
Collar Dia : (I) 30.85
(II) 31.85
Collar Height : 13.00

Reference Part Nos. : 092100 - 1551
Application: Mitsubishi : 4D31 ("G" TYPE)

FEED PUMPS

00.1063.400

Reference Part Nos. : 092100-3460



Roller Dia - 15.00
 Roller Thickness - 8.80
 Height From flange to top of Roller- 22.65
 Collar Dia (I) 31.00
 (II) 31.85
 Collar Height - 9.80
 Tappet Thickness - 16.00
 Tappet Height From flange - 21.50

00.1023.000



SHANDONG/30

00.1025.000



SHANDONG 2105/R

00.1026.000



SHANDONG 2105/X

00.1061.200



Reference Part No.:
 ZEXEL: 105220-2100

Application : Chinese 6 Cylinder Engine

00.1062.100



Reference Part Nos.:
 ZEXEL: 105220-4980

Application : Chinese 6 Cylinder Engine

LIFT PUMPS

00.1 140.000



Application

Deutz
BCD Reference No. 1662/7 32100511
Thread Size : M14 X 1.5

00.1141.000



Application

Fiat : 4757883
BCD Reference No. 1947/5, 1947/6
Thread Size : M12 X 1.5

00.1 142.000



Application

MF 265 (4 Cyl.)
Perkins : 4.236, 4.248, 2641711
BCD Reference No. 1873/5
Thread Size : ½" x 20 UNF

00.1 143.000



Application

MF 135 (3 Cyl.)
BCD Reference No. 1812
Thread Size : ½" x 20 UNF

00.1 144.000

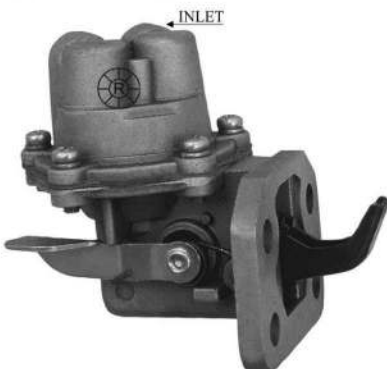

Application

MF 240 (3 Cyl.)
Perkins : 2641712
BCD Reference No. 1987
Thread Size : ½" x 20 UNF

00.1 145.000



Ref org. No. CAT : 2010877

Application

Perkins : 4.245, Perkins Phaser
BCD Reference No. 2566
Thread Size : ½" x 20 UNF

LIFT PUMPS

00.1 146.000

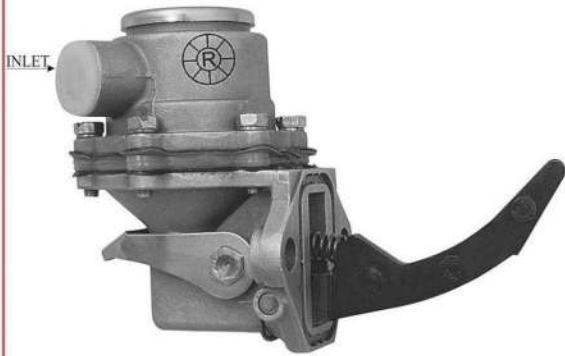

Application

SAME : 2 4519 3100
Thread Size : M14 x 1.5

00.1 147.000



Application

Iveco : 4757884
BCD Reference No. 1949/5
Thread Size : M12 x 1.5

00.1 148.000



Application

MF 265 (MF 4 CYL.)
Perkins 4.236, 4.248
BCD Reference No.1873/5
Thread Size : 1/2"x 20UNF

00.1 149.000

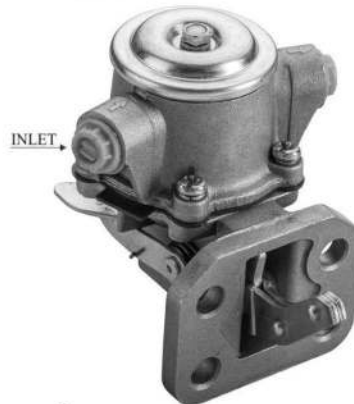

Thread Size : 1/2"x 20UNF

00.1 150.000



Thread Size : M12 X 1.25
Perkins 4.236

00.1 151.000



Thread Size : M12 X 1.25
Perkins 3.152

LIFT PUMPS

00.1 152.000



Thread Size : M12 X 1.25
Perkins : 3.152

00.1153.000



Application

Iveco : 4757884
BCD Reference No. 1949/5
Thread Size : M12 x 1.5

Similar to 00.1147.000
Orientation as per 00.1146.00

00.1 155.000



Thread Size : 1/2" x 20UNF

00.1 160.000



Application

Ford 5000, 6600, 6610
Perkins : 4.236TA
BCD Reference No. 1533/2A, 1693/1
Thread Size : 1/2" x 20UNF

00.1 161.000



Application

Ford 2700
BCD Reference No. 1686
Thread Size : 1/2" x 20UNF

00.1 162.000



Thread Size : 1/2" x 20UNF

00.1 163.000

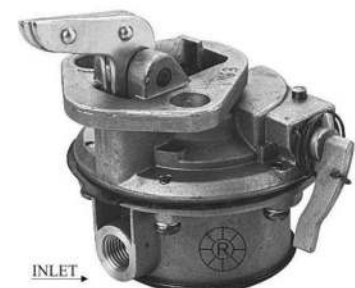

Thread Size : 1/2" x 20UNF

LIFT PUMPS

00.1 165.000

1/4 BSP x 19TPI

INLET →

M14 x 1.5



Application

Cummins 4 BT

00.1175.000



Application

Ref org. No. JCB 320/07201

00.1171.000



Application

Lister Petter 20146298

Thread Size : 1/2" UNF

00.1172.000



Application

Lister Petter 20146299

Thread Size : 1/2" UNF

00.1174.000



Application

Lister Petter 75714176

Thread Size : 1/2" UNF

00.1176.000

INLET →



Application

Lister Petter 75714175

Thread Size : 1/2" UNF

FEED PUMPS

00.1 200.000



Application 393 2226

Cummins 6BT
Inlet : M12 x 1.5
Outlet : M14 x 1.5

00.1 201.000



Application

Cummins 6BT
Inlet : M14 x 1.5
Outlet : M14 x 1.5

00.1 202.000



Application 391 7999

Cummins 6BT
Inlet : 1/4 x NPTF
Outlet : M14 x 1.5

00.1 210.000



Application

Cummins 6CT, 6CTA, 6CTAA, 6C
Inlet : 1/2 x 14H (NPTF)
Outlet : M14 x 1.5

393 2224
393 2225
393 3252
393 3253
393 6317
494 4711

00.1 211.000



Application

Cummins 6CT
Inlet : 1/4 x 18H (NPTF)
Outlet : M14 x 1.5

390 6795
393 6318 391 7998
393 6319 391 8076
393 0202 393 0201
393 2226
393 3254

00.1223.000



Application

F 002 A50 023
Thread : M 14 x 1.5 Intel & Outlet

FEED PUMPS

00.1225.354

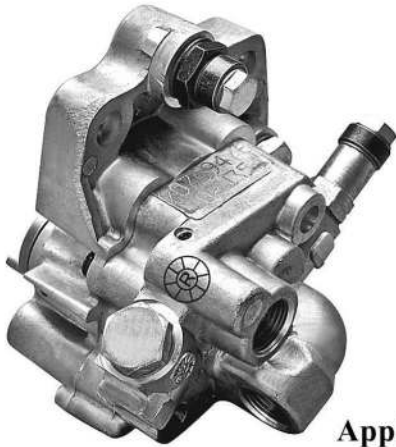

Application

VOLVO
20769476 0811354

00.1227.955



Application

VOLVO
21057955 07W 462 23125

00.1257.000



Application

SCANIA
0 440 020 057

FILTER COVERS WITH PRIMER

00.1 350.000



Application
Thread Size : M20 X 1.5

00.1 351.000



Application
Thread Size : UNF 3/4" X 16 TPI

00.1380.000



Reference Part Nos.
CAV : 9001-742G
Side Holes
Thread Size : M14 x 1.5

00.1390.000



Reference Part Nos.
CAV : 9001-742B (Roto/D SX Type)
Side Holes
Thread Size : M14 x 1.5

00.1391.000



Reference Part Nos.
CAV : 9001-742A (Roto/D DX Type)
Side Holes
Thread Size : M14 x 1.5

00.1398.000



Reference Part Nos.
CAV : 7176-231 BH (0 450 126 009)
Side Holes
Thread Size : M14 x 1.5

00.1399.000

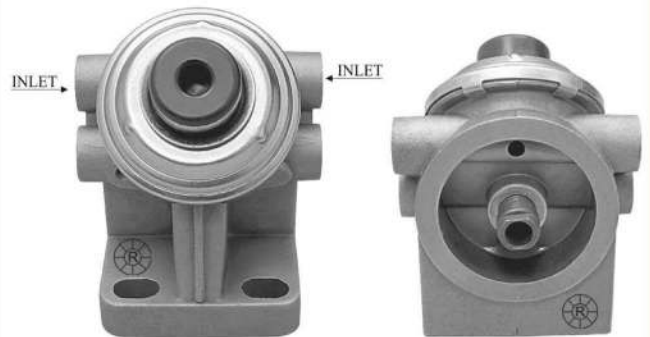

Side Holes
Thread Size : M14 x 1.5

FILTER COVERS WITH PRIMER

00.1381.000

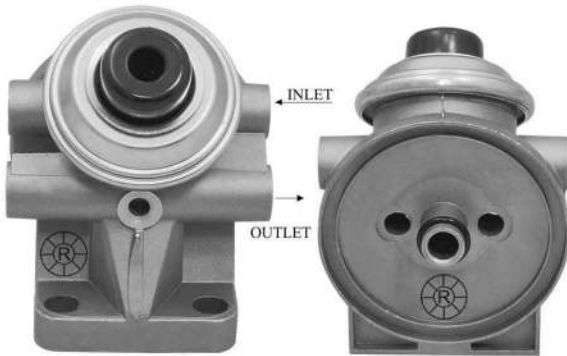

Application

Inlet - Left

Outlet - Left

Side Holes

Thread Size : M14 x 1.5

00.1382.000

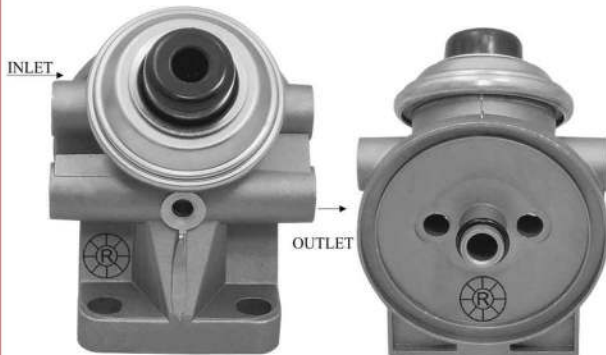

Application

Inlet - Right

Outlet - Left

Side Holes

Thread Size : M14 x 1.5

00.1383.000



Application

Inlet - Left

Outlet - Right

Side Holes

Thread Size : M14 x 1.5

PARTS OF C.I. FEED PUMPS

00.2 018.000



Dimension : 5 x 32.5

00.2 019.000



Dimension : 5 x 38
Bosch Repl. No. :
1 443 100 501

00.2 020.000



FEED PUMP PIN OLD MODEL
Bosch Repl. No. : 2 443 100 000,
2 449 998 313, 2 449 998 314
Dimension : 5 x 35

Sizes : Std 4.98, 1st 4.99, 2nd 5.00, 3rd 5.01, 4th 5.02nd 5.03,
6th 5.04, 7th 5.05, 8th 5.06, 9th 5.07, 10th 5.08

00.2 021.000

FEED PUMP PIN NEW MODEL



Dimension : 7 x 53.5

Sizes : Std 6.98, 1st 6.99, 2nd 7.00, 3rd 7.01, 4th 7.02, 5th 7.03,
6th 7.04, 7th 7.05, 8th 7.06, 9th 7.07, 10th 7.08

00.2 022.022

FEED PUMP PIN HEAD TYPE



Reference Org. Nos. : 2 443 120 022
Dimension : 7 x 48 (53)

Sizes : ... 6.98, 1st 6.99, 2nd 7.00, 3rd 7.01, 4th 7.02, 5th 7.03,
6th 7.04, 7th 7.05, 8th 7.06, 9th 7.07, 10th 7.08

00.2 025.000 (Zexel type)



Dimension : 10 x 41.3

00.2 002. 709 (Bosch type)



Bosch Repl. No. : 2 449 998 709 (std), 2 449 998 711 (2nd),
2 449 998 713 (3rd),

Sizes : Std 21.97, 1st 21.98, 2nd 21.99, 3rd 22.00, 4th 22.01, 5th 22.02, 6th 22.03,
7th 22.04, 8th 22.05, 9th 22.06, 10th 22.07, 11th 22.08, 12th 22.09, 13th 22.10,
14th 22.11, 15th 22.12, 16th 22.13, 17th 22.14, 18th 22.15, 19th 22.16, 20th 22.17,
21st 22.18, 22nd 22.19, 23rd 22.20, 24th 22.21, 25th 22.22

00.2 003. 000



Sizes : Std 21.97, 1st 21.98, 2nd 21.99, 3rd 22.00, 4th 22.01, 5th 22.02, 6th 22.03,
7th 22.04, 8th 22.05, 9th 22.06, 10th 22.07, 11th 22.08, 12th 22.09, 13th 22.10,
14th 22.11, 15th 22.12, 16th 22.13, 17th 22.14, 18th 22.15, 19th 22.16, 20th 22.17,
21st 22.18, 22nd 22.19, 23rd 22.20, 24th 22.21, 25th 22.22

01.8 010.001



Open Nut Bosch Type

OD - 16x1.5
ID - 14x1.5
Hex A/F - 19

Reference Org. Nos : 2 443 355 001

01.8 010.100



Open Nut Zexel Type

OD - 16x1.5
ID - 14x1.5
Hex A/F - 24

01.8 011.009



Close Nut

OD - 16x1.5
ID - 7.15
Hex A/F - 19

Reference Org. Nos. : 2 443 462 009

PARTS OF C.I. FEED PUMPS

01.8 012.014



Dog Nut

OD - 26x1.5
ID - 20
Hex A/F - 30

Reference Org. Nos. : 2 443 462 014

00.6 300.010

Feed Pump Piston Spring



Reference Org. No :
2 449 617 010

00.6 301.002

Feed Pump Piston Spring



Reference Org. No :
2 444 618 002

00.6 310.006

Feed Pump Valve Spring

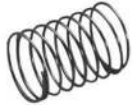

Reference Org. No :
2 444 615 006

00.4 720.005

Feed Pump Rubber Gasket



Reference Org. No: 2 440 109 005
ID OD TH
27.50 36.20 2.50

00.4 400.011

Nylon Prefilter (Strainer)



Reference Org. No:
1 450 410 011

00.6 320.001

Prefilter Spring



Reference Org. No:
2 454 642 001

00.4 530.002

Glass Bowl for Feed Pump



Reference Org. No. :
2 459 999 002, 000 091 0040

00.4 535.000

Aluminium Bowl for Feed Pump



Reference Org. No. :
2 450 556 000

01.9 001.000

Clamp for Feed Pump



Reference Org. No:
2 459 999 000

01.7 001.001

Stud Bolt



Reference Org. No. :
2 453 405 001

01.8 001.000

Clamping Nut



Reference Org. No. :
2 453 345 000

00.6 105.000

Tappet Body 'K' Type



00.6 120.005

Tappet Assy 'A' type for Feed Pump



Reference Org. No. :
2 447 010 005

00.6 121.101

Tappet Body 'A' type for Feed Pump



Reference Org. No. :
9 441 032 101, 2 442 120 011

PARTS OF C.I. FEED PUMPS

00.6 330.000

Circlip



Reference Org. No.:
2 444 601 000

01.9 110.001

Slider ('A' type)



Reference Org. No.:
2 443 120 001, 2 443 120 007

01.9 111.008

Slider ('P' type)



Reference Org. No.:
2 443 120 008

00.6 130.012

Tappet Assy 'P' type
for Feed Pump



Reference Org. No.:
2 447 010 012, 2 447 010 002

00.6 131.000

Tappet Body 'P' type
for Feed Pump



Reference Org. No.:
2 442 120 013

00.6 500.000

Feed Pump Gasket



Reference Org. No.:
1 411 073 000

Feed Pump Valve



No.	Mat	Channels	Top	Colour	O.E NOS.
00.8 101.010	Nylon	1	Groove	Brown	2 443 203 001
00.8 101.020	Nylon	1	Groove	White	1 900 210 100
00.8 103.010	Nylon	3	Groove	Brown	
00.8 103.020	Nylon	3	Groove	White	2 440 210 009
00.8 111.010	Bakelite	1	Groove	Brown	
00.8 111.030	Bakelite	1	Groove	Cherry	
00.8 111.110	Bakelite	1	Plain	Brown	
00.8 111.130	Bakelite	1	Plain	Cherry	
00.8 113.010	Bakelite	3	Groove	Brown	2 443 123 021
00.8 113.030	Bakelite	3	Groove	Cherry	

00.4 805.160

O Ring Old Model



Reference Org. No. : 1 900 210 000

ID TH
5 1.60

00.4 807.151

O Ring New Model



ID TH
7.20 1.50

PARTS OF ALUMINIUM FEED PUMPS

00.2 060.000

Sliding Tappet Bush (Guide Bush)



'A' type

00.2 061.005

Sliding Tappet Bush (Guide Bush)



'P' type

Reference Org. No :
443 461 005

00.2 024.024

Feed Pump Pin Head Type



Head Dia: 11.50mm
OD Length
7 34.7(37.5)

00.2 028.028

Feed Pump Pin Head Type



Head Dia: 13.50mm
OD Length
7 37.00(40.00)

Reference Org. No :
2 443 120 028

00.2 026.026

Feed Pump Pin Head Type



Head Dia: 11.50mm
OD Length
7 29.00(32.00)

Reference Org. No :
2 443 120 026

00.6 305.000

Spring for Aluminium Feed Pump



00.2 004.026

Piston for Aluminium Feed Pumps



Reference Org. No. : 2 440 520 026

Sizes : Std 23.97, 1st 23.98, 2nd 23.99, 3rd 24.00, 4th 24.01, 5th 24.02, 6th 24.03, 7th 24.04, 8th 24.05, 9th 24.06, 10th 24.07, 11th 24.08, 12th 24.09, 13th 24.10, 14th 24.11, 15th 24.12, 16th 24.13, 17th 24.14, 18th 24.15, 19th 24.16, 20th 24.17, 21th 24.18, 22th 24.19, 23th 24.20, 24th 24.21, 25th 24.22

01.8 524.140

Adopter with A.C. Valve



OD Thread - 24x1.50
ID Thread - 14x1.50
Hex - 23.00

01.8 522.140



Adopter with A.C. Valve

OD Thread - 22x1.50
ID Thread - 14x1.50
Hex A/F - 22.00

01.8 520.140



Adopter

OD Thread - 20x1.50
ID Thread - 14x1.50
Collar Round - 23.00

01.8 522.160



Adopter

OD Thread - 22x1.50
ID Thread - 16x1.50
Collar Round - 27.00

00.2 008.000



Piston 2011

REPAIR KITS FOR FEED PUMPS

00.2 101.000



Parts in the kits

	OE Nos.	Rajnish Nos.
F.P. Packing Gasket (1 pc)	: 1 411 073 000	00.6500.000
Bowl Rubber Washer (1 pc)	: 2 440 101 005, 2 440 109 005	00.4720.005
Closing Nut Copper Washer (1 pc)	: 2 440 105 000	02.2630.100
Hand Primer Washer 16x19.5x1 (2 pcs)	: 1 230 203 001	02.1619.101
Banjo Washer Copper 14x18x1 (4 pcs)	: 2 916 710 609, 2 916 710 610	02.1418.100
F.P. Valve (2 pcs)	: 2 443 203 001	Valve Section
F.P. Valve Spring (2 pcs)	: 2 444 615 006	00.6310.006
F.P. Rubber 'O' Ring (1 pc)	: 1 900 210 000	00.4805.160
Spring Lock Ring (1 pc)	: 2 444 601 000	00.6330.000

00.2 102.017



Reference Org. Part Nos.

Bosch	-	2 447 010 017 (with Glass Bowl).
Bosch	-	2 447 010 018 (with Aluminium Bowl).
Mercedes	-	000 091 08 40.

Parts in the Kits

	OE Nos.	Rajnish Nos
Pre Filter Bowl Gasket (Rubber)	- 2 440 109 005	00.4720.005
Nylon Pre Filter	- 1 450 410 011	00.4400.011
Filter Spring	- 2 454 642 001	00.6320.001
Aluminium Bowl OR	- 2 450 556 000	00.4535.000
Glass Bowl	- 2 459 999 002	00.4530.002
	000 091 0040	

00.2 103.027



Reference Part Nos.

Bosch	:	2 447 010 027
Merc.	:	000 091 0541
Merc.	:	000 090 0357
Merc.	:	000 990 0805

Parts in the kit

	OE Nos.	Rajnish Nos.
Locking Clamp	: 2 459 990 000	01.9001.000
Stud Bolt	: 2 453 405 001	01.7001.001
Clamping Nut	: 2 453 345 000	01.8001.000

00.2 113.000



00.2 114.000



For Prefilter
Assembly Big 00.4502.000

REPAIR KITS FOR FEED PUMPS

00.2 104.000



Parts in the Kits	OE Nos.	Rajnish Nos.
Feed Pump Pin	- 2 449 998 313	00.2020.000
Feed Pump Plunger	- 2 449 998 709, 2 449 998 714	00.2002.709
Feed Pump Plunger Spring	- 2 449 617 010	00.6300.010
Feed Pump Roller	- 2 440 200 000,	00.6008.100
Feed Pump Roller Pin	- 2 443 100 083	00.6008.300

00.2 105.000



Parts in the Kits	OE Nos.	Rajnish Nos.
Glass Bowl	- 2 459 999 002, 000 091 0040	00.4530.002
Nylon Pre Filter	- 1 450 410 011	00.4400.011
Filter Spring	- 2 454 642 001	00.6320.001
Pre Filter Bowl Gasket (Rubber)	- 2 440 109 005	00.4720.005
Locking Clamp	- 2 459 990 000	01.9001.000
Clamping Nut	- 2 453 345 000	01.8001.000
Stud Bolt	- 2 453 405 001	01.7001.001

00.2 106.016



Reference Part Nos.

Bosch	:	2 447 010 016
Merc.	:	000 090 0151

Parts in the kits	OE Nos.	Rajnish Nos.
Nylon Pre Filter (Strainer)	: 1 450 410 011	00.4400.011
Filter Spring	: 2 454 642 001	00.6320.001
Bowl Rubber Gasket	: 2 440 109 005	00.4720.005

00.2 107.000



Parts in the Kits	OE Nos.	Rajnish Nos.
F.P. Packing Gasket (1 pcs)	- 1 411 073 000	00.6500.000
Bowl Rubber Washer (1 pcs)	- 2 440 109 005	00.4720.005
Closing Nut Copper washer (1 pcs)	- 2 440 105 000	00.2630.100
Hand Primer Washer (16x19.5x1mm) (2 pcs)	- 1 230 203 001	02.1619.101
Banjo Washer Copper (14x18x1mm) (4 pcs)	- 2 916 710 609, 2 916 710 610	02.1418.100
F.P. Valve (2 pcs)	- 2 443 203 001	Valve section
F.P. Valve Spring (2 pcs)	- 2 444 615 006	00.6310.006
F.P. Rubber 'O' Ring (1 pcs)	- 1 900 210 000	00.4805.160
Spring Lock Ring (1 pcs)	- 2 444 601 000	00.6330.000
Spring Washer (3 pcs)		
Flange Nut (3 pcs)		

REPAIR KITS FOR FEED PUMPS

00.2 108.004



Reference Org. Part Nos.

Bosch : 2 447 010 004.

Parts in the Kits	OE Nos.	Rajnish Nos.
F.P. Packing Gasket (1 pcs)	- 1 411 073 000	00.6500.000
F.P. Valve (2 pcs)	- 2 443 203 001	Valve section
F.P. Valve Spring (2 pcs)	- 2 444 615 006	00.6310.006
Hand Primer Washer (16x19.5x1mm) (2 pcs)	- 1 230 203 001	02.1619.101
Banjo Washer Copper (14x18x1mm) (4 pcs)	- 2 916 710 609, 2 916 710 610	02.1418.100
F.P. Closing Nut Copper Washer (1 pcs)	- 2 440 105 000	02.2630.100
F.P. Rubber 'O' Ring (1 pcs)	- 1 900 210 000	00.4805.160
Banjo Dust Cap (2 pcs)		Dust cap sect

00.2 109.000



Parts in the kits	OE Nos.	Rajnish Nos.
H.P. Washer 16x19.5x1 (2 pcs)	: 1 230 203 001	02.1619.101
F.P. Valve (2 pcs)	: 2 443 203 001	Valve section
F.P. Valve Spring (2 pcs)	: 2 444 615 006	00.6310.006
Closing Nut Washer (1 pcs)	: 2 440 105 000	02.2630.100
F.P. Gasket (1 pcs)	: 1 411 073 000	00.6500.000

00.2 110.011



Reference Part Nos.

Merc. : 000 090 02 10.
Bosch : 2 447 010 011.

Parts in the kits	OE Nos.	Rajnish Nos.
H.P. Washer 16x19.5x1 (2 pcs)	: 1 230 203 001	02.1619.101
F.P. Valve (2 pcs)	: 2 443 203 001	Valve Section
F.P. Valve Spring (2 pcs)	: 2 444 615 006	00.6310.006

00.2 111.000



Parts in the Kits	OE Nos.	Rajnish Nos.
Glass Bowl	- 2 459 999 002, 000 091 0040	00.4530.002
Nylon Pre Filter	- 1 450 410 011	00.4400.011
F.P. Valve (2 pcs)	- 2 443 203 001	Valve Section
F.P. Valve Spring (2 pcs)	- 2 444 615 006	00.6310.006
Prefilter Bowl Gasket (Rubber)	- 2 440 109 005	00.4720.005

REPAIR KITS FOR FEED PUMPS

00.2 112.019



Reference Part Nos.

Bosch : 2 447 010 019

00.2 115.004



Parts in the kits

Dust Cap with Flap (white)	2 pcs
F.P. Valve Nylon 1 channel	2 pcs
F.P. Valve Spring	2 pcs
Copper Washer 26x29.5x1	1 pcs
Copper Washer 14x18x1.5	4 pcs
Copper Washer 16x19.5x1	1 pcs
O Ring (Green) ID-5, Thickness-1.5	1 pcs

00.2116.000



Reference Part Nos.

Bosch : 2447 010 003

00.2 120.000



Reference Part Nos.

Mercedes : 000 090 3303

00.2 122.000



Reference Part Nos.

Mercedes : 000 090 0751

00.2 125.035



Reference Part Nos.

Bosch : 2 447 010 035

00.2 126.000



Reference Part Nos.

Bosch : 2 447 010 042

REPAIR KITS FOR FEED PUMPS

00.2 130.021



Reference Part Nos.

Bosch : 2 447 010 021

Parts in the Kits

Item	Size	Quantity
O Ring	(20x2.5)	(1pcs)
O Ring	(22x2.5)	(1pcs)
O Ring	(7x1.5)	(1pcs)
A.C. Valve	(18mm)	(2pcs)

000.2129.000



Reference Part Nos.

Bosch : 2 447 010 010

18mm Ac Valve
16.60 x 2.40 - O - ring

00.2 131.043



Reference Part Nos.

Bosch : 2 447 010 043

Parts in the Kits

Item	Size	Quantity
O Ring	(22x2.5 Viton)	(1pcs)
O Ring	(17.5x2.5 Viton)	(1pcs)
O Ring	(7x1.5 Viton)	(1pcs)
A.C. Valve	(18mm)	(1pcs)
Adopter with A.C. Valve	18mm	(1 pcs)
With Thread size	22 x 1.5	

00.2 132.000



Reference Part Nos.

Bosch :

Parts in the Kits

Item	Size	Quantity
O Ring	(22x2.5 Viton)	(1pcs)
O Ring	(17.5x2.5 Viton)	(1pcs)
O Ring	(7x1.5 Viton)	(1pcs)
A.C. Valve	(18mm)	(1pcs)
Adopter with A.C. Valve	18mm	(1 pcs)
With Thread size	24 x 1.5	

00.2 133.037



Reference Part Nos.

2 447 010 37

00.2140.000



VOLVO

REPAIR KITS FOR VE & ROTARY PUMPS

00.2 201.000

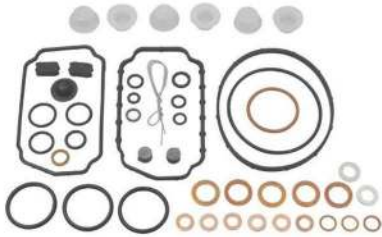

Reference Part Nos.

Bosch : 1 467 010 059

Zexel : 146600-1120

VE KIT

00.2 202.307



VE KIT

With Oil Seal 20x30x7

00.2 203.317



VE KIT

With Oil Seal 20x31x7

Reference Part No.

Bosch : 1 467 010 520

00.2 204.287



VE KIT

With Oil Seal 17x28 x7

00.2 225.000



Reference Part Nos. : 9109.230

00.2 226.000



CAV

Reference Part Nos. : 7135 110

MF

REPAIR KITS FOR INLINE PUMPS

00.2 301.000



RSV
Reference Part Nos.
 Bosch : 1 427 010 003

00.2 302.000



RQV
Reference Part Nos.
 Bosch : 1 427 010 002

00.2 305.000



00.2 306.000



00.2 310.000



A6
Reference Part Nos.
 Bosch : 1 417 010 003
 Bosch : 1 417 010 010

00.2 312.000

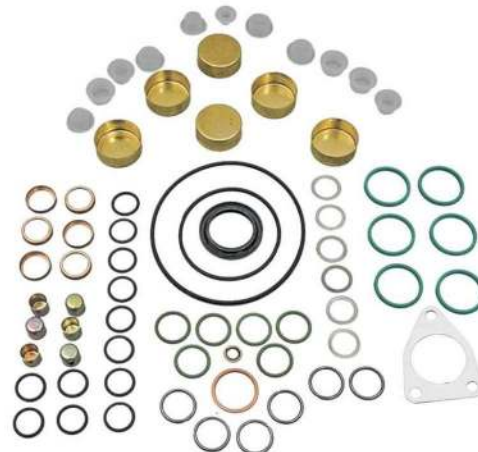

Reference Part Nos.
 (PE) S 6P S7100 / S7800
 Bosch : 2 417 010 010

REPAIR KITS FOR INLINE PUMPS

00.2 315.000



P6

Reference Part Nos.

Bosch : 2 417 010 001

00.2 320.000



P8

Reference Part Nos.

Bosch : 2 417 010 003

00.2 313.000



00.2 325.000



00.2 326.000



00.2 327.000



00.2 350.000



Reference Part Nos.

Bosch : F 00H N37 069

PARTS OF PUMPS (PE / PF / VE / CR)

C.R KITS

00.2 355.000

Application : CPI



00.2 375.000

Application : Denso HP3 Pumps

294009 - 0031/030

With Oil Seal 20X30X7 (VITON)



00.2 356.000

Application : CPIH

With Oil Seal 20X31X7 (VITON) & SCREWS



00.2 370.000

Application : CP3 70

With Oil Seal 20X31X7 (VITON)

With Oil Seal 10X19X5



00.2 365.000

Application : Delphi Pumps

7135 - 539

With Oil Seal 20X32X6 / 20X33X6 (VITON)

MRP ₹ 360.00

Oil Seal ₹ 100.00 Per Pc.



00.2 380.000

Application : CP3 80

With Oil Seal 25X36X7.5 VITON (F 00R 0P0 521)

With Oil Seal 25X37X7 VITON (F 00N 202 337)

With Oil Seal 10X19X5



00.2 366.000

Application : DELPHI RING KIT

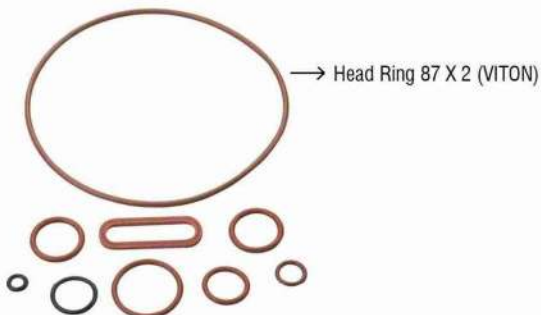

00.2 380.500

Similar to 00.2380.000

But without Oil Seals

Ref Org no. F00N 201 974

HAND PRIMERS

00.3 001.202



00.3 001.210 (GG)



00.3 001.211(ZG)



00.3 001.500(AL)



Reference Part nos.

MICO - 9 441 037 202 (Black, Golden(G) or Zinc(Z)) M 16x1.5

00.3 002.000



00.3 003.000



Reference Part Nos.

“MOTORPAL” TYPE - Thread M 14x1.5

Thread M 16x1.5

00.3 005.000



00.3 005.300(SC)



00.3 005.500(AL)



Reference Part Nos.

BOSCH	2 447 222 000
MERCEDES-BENZ	000 091 11 01
MAN	81 12150 6001
KHD	8747 02 02 10, 215 9346
DAF	194194
RENAULT	00 03 020 503
FIAT	746189
LANCIA	746189
BERLIET	3 020 503

DRESSER	684 492 C 93
HATZ	49017700
IH (INTERNATIONAL HARV.)	684 492 C 92
IH (INTERNATIONAL HARV.)	684 492 C 93
MACK (TRUCKS)	9352447222000
MTU	000 091 11 01
MWM – DIESEL	6 0690 58 1 0101
VALMET	123 010

HAND PRIMERS

00.3 006.000



Reference Part Nos.

ZEXEL 152200 - 1120
NIPPON DENSO 092130 - 0050

00.3 006.300 (SC)



00.3 007.000 (BIG NIPPLE)



Reference Part Nos.

ZEXEL 152200 - 5420

00.3 008.000



M16 X 1.0

00.3 011.001



**Steel Body
Aluminium Knob**

00.3 012.001



**Steel Long Body,
Aluminium Diecast Cap**

Reference Part Nos.

BOSCH : 2 447 222 001
LANCIA : 748959
FIAT : 748959

00.3 013.000



00.3 017.000 (F)



Ford Thread M 24.5 x1.5

00.3 018.000



**9001 / 090 A, 52244019
Thread M 23x1.00
Roto Diesel :**

00.3 019.000



CAV Type Thread M 24x1.00

HAND PRIMERS

00.3 020.000



Reference Part Nos.

BOSCH	2 447 222 020
MERCEDES-BENZ	001 091 45 01
VOLVO	76703, 7076703
MAN	11 21508 0001, 81 12150 6003, 51 12150 7003
SCANIA	192882
IVECO	1266727
KHD	126 6727, 126 6726, 1201 8574
DAF	248559

00.3 021.000



Aluminium (spring type)

Reference Part Nos.
 Zexel - 152200-5620
 ND - 092130-0220

00.3 022.000



Aluminium

Reference Part Nos.
 Zexel : 086120-0022 (Thread 24x1)

00.3 023.000



Shell Type

00.3 025.000



Reference Part Nos.
 Bosch 2 447 222 025
 Bosch 2 447 010 030

00.3 031.000



Aluminium (Spring type)

Reference Part Nos.
 ND - 086120-0031 (Thread 24x1)
 Bottom Hole - 7.50

00.3 032.000



Aluminium
Reference Part Nos.
 Caterpillar : 51 - 7511

HAND PRIMERS

00.3 033.000



Reference Part Nos.

BOSCH	2 447 010 033 (with washer)
BOSCH	2 447 222 125 (without washer)
VOLVO	3826073
MAN	81 12150 6013
SCANIA	1384501
KHD	131 9147, 1201 8574
RENAULT	50 01 834 118
DAF	1311608
FENDT	F 824 200 711 220

00.3 034.000



Thread : 14x1.5
Motorpal Type

00.3 045.000



Reference Part Nos.

BOSCH : 2 447 010 045
(with converter M 22 x 1)

00.3 051.000



00.3 099.XXX



00.3 099.000 Steel cap zinc colour
00.3 099.500 Aluminium cap

Reference Part Nos.

BOSCH	2 447 222 099
MERCEDES-BENZ	000 091 14 90
VOLVO	843435, 76703
MAN	81 12550 7002, 51 12151 7002,
MAN	51 12150 7002, 11 21508 0005
SCANIA	192882
KHD	126 2537, 1203 8345, 1202 8345, 1507 0157
DAF	608932
CATERPILLAR	2Y 5797
MWM-DIESEL	3 0520 99 0 0028, 6 0520 20 7 0003
MWM-DIESEL	9 0690 58 1 0101, 15070157

00.3 100.XXX



00.3 100.000 Steel cap zinc colour
00.3 100.500 Aluminium cap

00.3 200.XXX (Long)



00.3200.000 Steel Cap Zinc Color
00.3200.500 Aluminium Cap

HAND PRIMERS

00.3014.000



Thread:- 24X1

00.3015.000



Thread:- 24X1.5

00.3016.000



Thread:- 24X1.5

RACKS & GEARS

00.4 001.000



Rack "A" type (9mm)

00.4 001.008 (4 001 A)



Rack "A" type (11mm)
Reference Org. Nos. : 1 416 021 008

00.4 001.021 (4 001 B)



Rack "B" type
Reference Org. Nos. : 9 411 036 021

00.4 001.500 (4 001 R)



Rack Andoria

00.4 002.012 (4 002 S)



Two Cylinder Small-2511
Reference Part Nos.
Mico : 9 411 036 012

00.4 002.018 (4 002 L)



Two Cylinder "Long"
Reference Part Nos.
Mico : 1 416 022 018

00.4 003.006 (4 003 S)



Three Cylinder "Small"
Reference Part Nos.
Mico : 1 416 023 006

00.4 003.000 (4 003 L)



Three Cylinder "Long"
Reference Part Nos.
Mico : 1 416 023 000

00.4 003.200 (4 003 C)



Three Cylinder "CAV"

00.4 003.005 (4 003 O/M)



Reference Org. Nos. : 1 416 023 005

00.4 004.007 (4 004 S)



Four Cylinder "Small"
Reference Part Nos.
Mico : 1 416 024 007

00.4 004.006 (4 004 L)



Four Cylinder "Long"
Reference Part Nos.
Mico : 1 416 024 006

00.4 004.400 (4 004 2H)



Four Cylinder Two Hole

00.4 006.004 (4 006 S)



Six Cylinder "Small"
Reference Part Nos.
Mico : 1 416 026 004

00.4 006.005 (4 006 L)



Six Cylinder "Long"
Reference Part Nos.
Mico : 1 416 026 005

RACKS

00.4 001.700



Rack 1K Pin type

00.4 001.750



Rack 1K Ball type

00.4 001.760



Rack 1K Ball type with Notch

00.4 002.700



Rack 2K Pin type

00.4 002.710



Rack 2K Pin type with extra Pin

00.4 002.750



Rack 2K Ball type

00.4 003.700



Rack 3K Pin type

00.4 004.700



TOOTH QUADRANTS

00.4 101.062



Tooth Quadrant Mico - Bosch Type

Reference Part Nos.

Mico : 1 416 336 062, 060, 061

00.4 102.200



Tooth Quadrant "CAV" Type

PLUNGER SLEEVES

00.4 201.030



Bosch type

Reference Part Nos.

Mico : 1 410 326 030

Bore : 12mm

00.4 201.000



Plunger Sleeve

Reference Part Nos.

Mico : 1 410 326 030

Close Type, Bore 12 mm

00.4 202.601



Bore : 13mm

Leyland 402

Reference Org. No. F 002 A 10601

GEARS

00.4 211.000



GEAR 'B' Type

Reference Part Nos.

Mico : 1 410 364 000

00.4 211.019



GEAR 'A' Type

(Broach Type)

Reference Part Nos.

F002 F31 019

00.4 211.031



GEAR 'A' Type

Reference Part Nos.

Mico : 1 410 364 031

00.4 211.500



Gear Andoria

00.4 245.000
Bush Cap RSV STD



00.4 246.000
Bush Cap RSV/1st o/s



00.4 248.000
Sealing Cap



00.4 270.000
Accelerator Lever DI

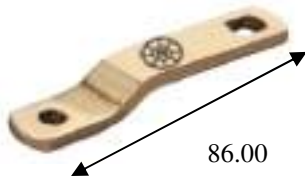

00.4 271.000
Accelerator Lever Leylend



00.4 272.000
Accelerator Lever 2511



00.4 273.000
Accelerator Lever Small P3



00.4 235.000
Element Lower Spring Plate



00.4 236.000
Element Upper Spring Plate



00.4 250.000
Accelerator Shaft Bush
00.4250 BR (Bronze)
00.4250 AS (Alloy Steel)



00.4 251.000
Accelerator Shaft Bush
00.4251 BR (Bronze)
00.4251 AS (Alloy Steel)



00.4 252.000
Accelerator Shaft Bush
00.4252 BR (Bronze)
00.4252 AS (Alloy Steel)



00.4 240.000



Control Rod Bush Roller Type

CAM SHAFTS

00.4525.000



CAM SHAFT
ROMANIA (UTB)
Reference No. 1 416 124 311
Total Length 236.50 mm

Products



Part No.	Type	Length	Keys	Special Features
00.4510.000	A	101		
00.4511.000	B	118	Straight	1 466 100 405
00.4512.000	B	118	Misaligned	
00.4513.000	B	110	Straight	
00.4514.000	B	110	Straight	Deep Hole in Back

SOLENOID SWITCHES

Bosch/Zexel TYPE



Volt	Roll Mark	Repl. No.		Rajnish Part Nos.
12V	12V 015	0 330 001 015	Bosch	00.4312.015
12V	12V 018	0 330 001 018	Bosch	00.4312.018
12V	12V 720	146650-720	Zexel	00.4312.720
12V	12V 122	146650-122	Zexel	00.4312.122
24V	24V 016	0 330 001 016	Bosch	00.4324.016
24V	24V 510	0 96010-0510	ND	00.4324.510

CAVTYPE



Volt	Roll Mark	Repl. No.		Rajnish Part Nos.
12V	12V 049	9 009-049 (MS Male Terminal)	Cav	00.4312.049
24V	24V 049	7180-049 (MS Male Terminal)	Cav	00.4324.049
12V	12V 620D	7167-620D		00.4312.620
12V	12V 620A	7167-620A		00.4312.621
12V	12V 520A	ND 096030-0520		00.4312.0520

FILTERS

00.4 400.011
Nylon Prefilter (Strainer)



Reference Org. No.:
1 450 410 011

00.4 402.000
Pre Filter Brass



00.4 403.003
Brass Filter for Banjo Bolt



Bosch No. - 2 440 401 003

00.4 404.000



00.4 407.000



00.4 410.000



OD:20.30
Height:17.60
Bottom Closed

00.4 411.000



OD:20.30
Height:21.00

00.4 412.001



OD:20.30 Height:22.00

00.4 415.000



For Feed Pump
00. 1 050.000

00.4 416.000



Filter for 00.4 503.000

00.4 417.000



DPA FILTER

00.4 500.407



Reference No. :
9 451 037 407

00.4 500.409



Reference No. :
9 451 037 409

00.4 500.405



Reference No. :
9 451 037 405

00.4 500.406



Reference No. :
9 451 037 406

00.4 500.404



Reference No. :
9 451 037 404

00.4 500.003



Reference No. :
9 451 037 003

CAV



00.4 420.000



Filter Valve Assy DPC Type

PRE FILTER ASSEMBLIES & PARTS

00.4501.000



Pre Filter Assembly Small

Reference Part Nos.

Mico : 1 457 434 000 (with Glass Bowl)

Mico : 1 457 434 002 (with Aluminium Bowl)

00.9001.001



Pre Filter top small

Reference Part Nos. : 2 459 999 001

00.4502.000



Pre Filter Assembly Big
Reference Part Nos.

Iveco : 9932 337

Iveco Turbo Star : 4797 320

00.9002.000



Pre Filter top Big

00.4503.009



Pre Filter Assembly. N/M

Reference Part Nos.

Bosch : 2 457 434 009

00.9003.000



Pre Filter top N/M

00.4504.000



Motorpal Type
Prefilter Assembly

00.9004.000



Pre Filter top for
Motorpal Type
Prefilter Assembly (00.4504.000)

01.9002.000



Clamp for Big Prefilter Assembly
for (00 4502 000)

WATER SEPARATORS

00.4 505.000



Reference Part Nos.
CAV : 5864001
Iveco Turbo Star

Entry - Right
Thread : M14 x 1.5

00.4 505.100



Entry - Left
Thread : M14 x 1.5

00.4 505.200



Reference Part Nos.
CAV : 5864000

Entry - Right
Thread : UNF 1/2" x 20 TP1

00.4 505.300



Entry - Left
Thread : UNF 1/2" x 20 TP1

00.4 506.000



Entry - Right
Thread : M14 x 1.5

00.4 507.000



Entry - Left
Thread : M14 x 1.5

00.4510.100



Only Top 00.4510.000
Reference Part Nos.
F 002 H 20 392
Thread : M14 x 1.5 Intel & Outlet

PRE FILTER ASSEMBLIES & WATER SEPARATOR PARTS

00.4 530.002



Glass Bowl for Feed Pump
Reference Org. No.
2 459 999 002, 000 091 0040

00.4 535.000



Aluminium Bowl for Feed Pump

00.4540.000



Glass Bowl for Big Prefilter Assembly

00.4 545.000



Bowl for Water Separator 00.4 505.000 & 00.4 506.000

00.4 546.000



Spare Part for Water Separator 00.4 505.000 & 00.4 506.000

00.4 547.000



Bowl for Feed Pump 00.1 050.000

00.4 548.000



Bowl for 00.4 503.000

00.4 550.000



CAV Bowl

00.4 551.000



Glass Bowl
Ref. Part Nos.
CAV 7111 - 403

00.4 555.000



Bowl
Ref. Part Nos.
CAV Aluminum Bowl

RUBBER PACKINGS

00.4 702.082



Application - P2
Repl. No. - 1 411 015 082

00.4 703.013



Application - P3
Repl. No. - 9 411 031 013
1 411 015 083

00.4 704.104



Application - P4
Repl. No. - 1 411 015 104
1 411 015 084

00.4 706.097



Application - P6
Repl. No. - 1 411 015 097
1 411 015 086

00.4 720.005



Feed Pump Rubber Gasket
Reference Org. Nos. : 2 440 109 005
ID OD TH
27.50 36.20 2.50

00.4 721.000



Rubber Packing for Big Glass Bowl
ID OD TH
40.20 54.20 2.50

00.4 722.042



Rubber washer for Filter Assy 0.5 L
Reference Org. Nos. : 1 450 109 042

00.4 723.001



Rubber washer for Filter Assy 1.00 L
Reference Org. Nos. : 1 450 109 001
1 450 109 041

00.4 724.000



Rubber washer for Water Separators 00.4 505.000 & 00.4 506.000

00.4 725.000



'O' Ring for Kit 00.2120.751
ID OD TH
50 55 2.5

RUBBER PARTS

00.4 730.000



Damper (Rubber Segment)

Reference Org. No s. : 1 420 026 000, 1 420 026 004

Application : RQV

00.4 731.003



Damper (Rubber Segment)

Reference Org. Nos. : 2 420 026 003, 2 420 026 006

00.4 732.150



Damper (Rubber Segment)

Reference Part Nos. : 091337-0150
22723 - 68150

Application : Mitsubishi, Toyota

00.4 733.302



Length	Width	Height
16.2	9.00	5.4

Reference Part Nos. : 1 460 056 302
146202 0100

00.4 734.000



00.4 735.000



20.60X7.50X3.15

Reference Part Nos. : 7123 691

00.4 740.303

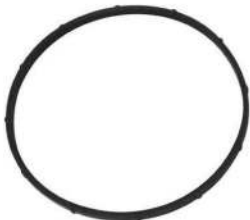

Reference Part Nos : 1 460 206 303

00.4 745.300



Reference Part Nos : 1 461 015 300

00.4 746.000



Reference Part Nos : 146600 4400 (Thin Type)

'O' RINGS



Inner Dia X Thickness

1 X 1	9 X 2.50	15 X 2	22 X 2	60 X 2.50
1.8 X 1	9.25 X 2.50	15 X 2.5	22 X 2.5	55 X 2
2.2 X 1	9 X 2.85	15.40 X 2.5	22 X 4	58 X 2
	9.15 X 1.70	15.25 X 2	22.60 X 3	58 X 3
4 X 1.5	9.10 X 1.70	15.10 X 1.80		65.50 X 1.70
4.5 X 2			24.15 X 2.5	52 X 1.50
4.25 X 2.5	10 X 2	16 X 2		45 X 4
4.98 X 1.65	10 X 2.20	16 X 2.5	25 X 2	106 X 2.5
	10 X 2.50	16 X 3	25 X 3	107 X 2.5
5 X 1.5	10.95 X 3.35	16.50 X 2.5	25 X 4	120 X 3.5
5 X 2	10.70 X 2			170 X 3
5.85 X 2.10		17 X 2	26 X 2	
5.30 X 2.5	11 X 2		26 X 2.5	
5.50 X 2	11 X 2.50	18 X 2	26.50 X 2.5	
5.50 X 2.5	11 X 2.75	18 X 2.50	26.50 X 1.75	
	11 X 3	18.50 X 2.50	26.10 X 1.85	
6 X 1	11.30 X 1.60	18.50 X 2.25		
6 X 2	11.50 X 1.50		27.7 X 2.55	
6 X 1.90	11 X 1.50	19 X 1.80		
6.50 X 2		19 X 2		
6.20 X 1.60	12 X 2	19.50 X 2.95	28 X 2.5	
	12 X 1.85		30 X 1.5	
7 X 1.5	12.20 X 1.65	20 X 1.50	30 X 2.5	
7 X 2	12.20 X 1.85	20 X 2	32 X 2	
7 X 2.5	12.50 X 1.80	20 X 2.5	33 X 3	
		20 X 3	38.3 X 2.6	
8.98 X 1.55	13 X 2		38 X 2.50	
8 X 2	13 X 2.5	21 X 1.85	45 X 4	
8 X 2.5	13 X 1.5	21.20 X 1.85	50 X 2	
8.50 X 2.5	13 X 3	21 X 2	50 X 2.5	
		21.60 X 2.25	51 X 2	
8.5 X 2	14 X 2	21 X 1.90	55 X 2	
	14 X 2.50	21 X 1.50	58 X 2	
	14 X 2.75		58 X 3	
	14 X 3		44 X 3	
			60 X 2.50	

Note : Other sizes are also available on demand

OIL SEALS

00.4 901.000



ID	OD	TH	Application
9.2	17.2	4	RQV Shaft 11mm

00.4 902.000



ID	OD	TH
10.6	18.2	5

00.4 903.570



Reference Org. Nos. : 949150-0570

ID	OD	TH
17	28	7

00.4 904.190



Reference Org. Nos. : 029622-0190

ID	OD	TH
20	30	7

00.4 905.100



Reference Org. Nos. : 9.461 615 373
(146601-0700 2301)

Reference Org. Nos. : 146601-0100

ID	OD	TH
20	31	7

00.4 906.400



For Zexel Feed Pump
5 x 14 x 5 029620-4000

00.4 907.000



25 x 35 x 7

00.4 908.000



10 x 17 x 4

00.4 909.000



28 x 38 x 6.3

GOVERNOR PARTS DIAPHRAGMS

00.5 000.000



Link Pin

00.5 001.001



Reference Part Nos.
Mico : 1 420 503 001 (EP ME 1/2 Z)
Application : P6

00.5 002.002



Reference Part Nos.
Mico : 1 420 503 002 (EP ME 1/3 Z)
Application : P3

00.5 003.549



Reference Part Nos.
Zexel : 155020-0920
Merc. : **OM 616**
9 421 030 549, 9 421 030 529

Application
Diesel Kiki Big
OM 616 – T1 Series

00.5 004.041

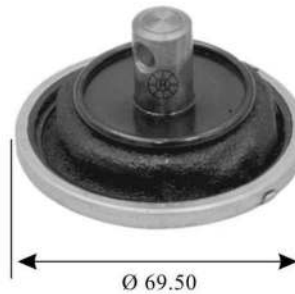

Application
Toyota BU, DAIHATSU, Toyota 3 B, Diesel
Kiki-Small Toyota BU

Reference Part Nos.

Zexel : 0 90580-0041 (ND)
Zexel : 155020-8420
Zexel : 155020-8620

Design : Rivetted, without spring,
copper colour pin & rivet

00.5 005.024

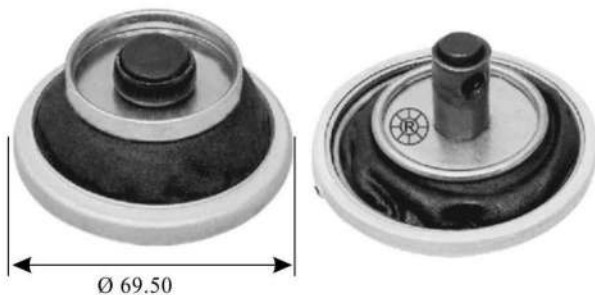

Reference Part Nos.
Zexel : 1 420 503 024

Design : Rivetted, with Rubber, with Spring, White plate,
Nippon Denso

00.5 006.920

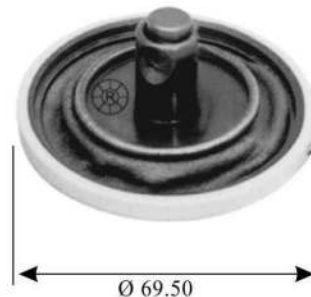

Reference Part Nos.
Zexel : 155020-8920
Zexel : 155020-7920
155020-2120

Design : Diesel Kiki – Small with spring

Application : Mercedes, ELF

GOVERNOR PARTS DIAPHRAGMS

00.5 007.000



CAV 7034-19 D
Application Leyland

00.5 008.000



CAV 7034-19 A
Application P6 CAV
Round Hole

00.5 010.000



00.5 009.000

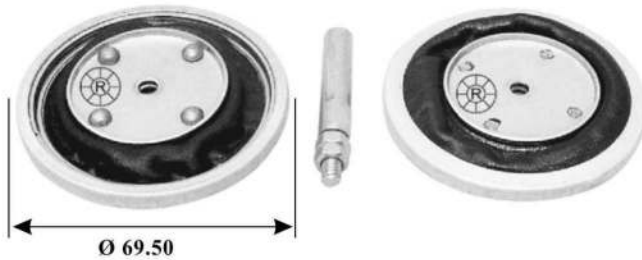

CAV 7034-19 B
Application : Bedford

00.5 011.022

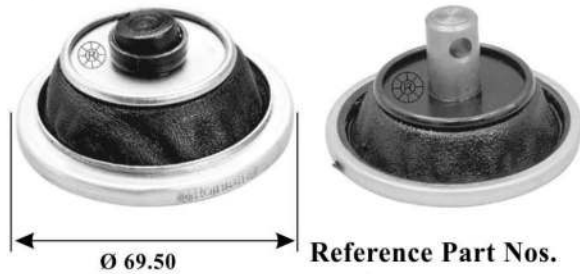

Reference Part Nos.
Zexel : 0 90580-0022 (ND)
Zexel : 0 90580-0011

Application : Toyota JK, Diesel kiki small with Rubber

00.5 012.000



Design : Rivetted with Spring, white plate,
without Rubber, Nippon Denso, Daihatsu
Reference No.: 1 420 503 022 Fiat - 765292

00.5 013.000



CAV 7034-19H

00.5 014.000



Reference Part Nos.:
154400- 7420
Hole dia - 8.20

00.5 015.000



Reference Part Nos.:
154400- 8220

00.5 016.000



Reference Part Nos.:
154400- 8521
Length of shaft : 31.90
Threaded portion of pin: 9.50

GOVERNOR PARTS DIAPHRAGMS

00.5025.000 (Membrane)



Diaphragm For 00.1143.000
00.1148.000

00.5026.000 (Membrane)



Diaphragm For 00.1141.000

GOVERNOR PARTS SWIVELLING LEVERS

00.5101.044



Swivelling Lever Right Long
Reference Org. Nos. : 1 422 013 044

00.5102.039



Swivelling Lever Left Long
Reference Org. Nos. : 1 422 013 039

00.5103.036



Swivelling Lever Both Side Equal
Reference Org. Nos. : 1 422 013 036

00.5104.118



Swivelling Lever Both Side Equal
Reference Org. Nos. : 1 422 013 118

GOVERNOR PARTS & AIR BREATHERS

00.5 201.000 (5201)



AIR BREATHER (Small)
Reference Part Nos.
Mico : 1 427 432 000

00.5 202.010 (5202)



AIR BREATHER (Big)
Reference Part Nos.
Mico : 1 427 432 010

GOVERNOR PARTS MISC

00.5 250.028 (5250)



BEARING ASSEMBLY (RSV)
Reference Part No
Mico : 1 420 322 028

01.7 030.024



Centre Bolt
Reference Part Nos. : 2 423 100 024

01.7 031.000



Governor Pin with Lock

00.5 301.019



FLY Weight Assembly Big
Reference Part Nos.: 1 428 194 019
Weight : 880- 900 gm

00.5 304.000



FLY Weight Assembly
Big with keyway

00.5 302.021



FLY Weight Assembly Small
Reference Part Nos.: 1 428 194 021
Weight : 735- 740 gm

00.5 303.000



Fly Weight Assembly
Small with keyway

00.5 305.000



00.5 306.000



FLY Weight Assembly
3610/2522

GOVERNOR PARTS

00.5 220.000

Gov. Weight Pin RSV

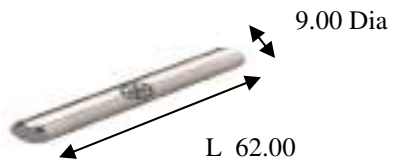

00.5 225.000

Gov. Fork Pin RSV

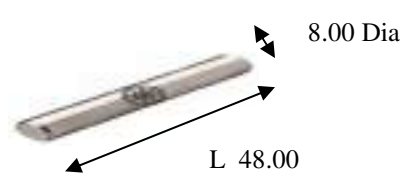

00.5 228.00

Gov. Square Pin Big



00.5 230.000

Gov. Square Pin Small



00.5 251.000

Square 3610



ID	OD	Thickness
8 x	16 x	5

GOVERNOR PARTS MISC

00.5 401.034



Swivelling Lever Bush Bosch Type
Reference Part Nos. : 1 420 328 034

00.5 402.000



9 421 611 611
154 204 - 0102
Swivelling Lever Bush Zexel Type

00.5 403.000



OD 20, ID 11, Length 20.6

00.5404.000



Reference Part Nos. : 154 204 4400

00.5 406.000



Swivelling Lever Bush Komatsu
Reference Org. No. : 9 421 610 939

00.5 120.080



Governor Housing Shaft RQV

Reference Part Nos.: 1 423 002 080

00.5 121.000



Governor Housing Shaft Mitsubishi PS 100

Over - Hole Kit
Reference Part Nos.: 190890-0780

00.5 122.000



00.5 123.030



Chowk Shaft T.C.

Reference Part Nos. : 1 423 002 030

00.5 124.000



Tach Shaft

Cummins

00.5 405.000



Bush for Governor Housing Shaft RQV

GOVERNOR ASSEMBLY

00.5 350.300



RSV Governor Left

00.5 351.000



00.5 352.000



RSV Governor Both Side Open

00.5 353.000



Governor Romania



Governor Romania

GOVERNOR ASSEMBLY

00.5 355.000



RSV Governor Left

00.5 356.000



RSV Governor Right

00.5357.000



RSV Governor Both

00.5361.302



Dir.: Left
Ref. Part No. : F 002 A21 302

00.5361.305



Dir.: Right
Ref. Part No. : F 002 A21 305

00.5 362.000



Dir.: Both Side Open
Ref. Part No

GOVERNOR ASSEMBLY

00.5 364.000



(Both Side Close)
Ref. Part Nos. : 1 425 621 001

00.5 365.000



With Hole Thread Size M 22 X 1.5



Governor Housing Inner
Ref. Part No. : 1 425 121 056
RSV

00.5 366.000



With Hole Thread Size M 22 X 1.5



With Drain Bush, Thread Size M 10 X 1

00.5370.000



Governor Housing Inner

GOVERNOR PARTS TIMING GEARS

00.5 500.000



Assembly

Application : 2011

00.5 500.100



Only Inner

00.5 500.200



Only Outer

00.5 501.000



Application : 2511

00.5 502.000



Application : 3511

00.5 503.000



Application : 5711

00.5 504.000



Application : 5911

00.5 505.000



Assembly

Application : H - 35

00.5 505.100



Only Inner

00.5 505.200



Only Outer

00.5 506.000



INTER

00.5 507.000



Hole Thread 8 x 1

ROLLERS

00.6 001.000 (6 001)

Tappet Roller Bush Pin "A" Type



Reference Org. Part Nos.

Bosch :	1 410 202 001	11 x 17 x 9 -	Roller	00.6 001.100
	1 410 300 050	7 x 11 x 9 -	Bush	00.6 001.200
	1 413 100 001	7 x 26.50 -	Pin	00.6 001.300

00.6 002.000 (6 002)

Tappet Roller Bush Pin "B" Type



Reference Org. Part Nos. 090180-0030

Bosch :	1 410 202 006	11 x 17 x 11 -	Roller	00.6 002.100
	1 410 300 042	7 x 11 x 11 -	Bush	00.6 002.200
	1 413 100 012	7 x 24 -	Pin	00.6 002.300

00.6 003.000 (6 003)

Tappet Roller & Pin "A" Type



7 x 17 x 9. -	Roller	00.6 003.100
7 x 26.50 -	Pin	00.6 003.300

00.6 004.000 (6 004)

Tappet Roller & Pin "B" Type



7 x 17 x 11 -	Roller	00.6 004.100
7 x 24 -	Pin	00.6 004.300

00.6 005.000 (6 005)

Tappet Roller & Pin 2011 (Motorpal)



9 x 18 x 10 -	Roller	00.6 005.100
9 x 26.50 -	Pin	00.6 005.300

00.6 006.000 (6 006)



Reference Org. Part Nos. Roller Bush Pin VE-Pumps

Kit	-	148210-5720
Bosch	-	1 410 202 005 (148212-0000)
Bosch	-	1 410 300 052 (148211-0000)
Bosch	-	1 410 100 021 (148211-0000)
Washers	-	(148214-0000)
11 x 15 x 7.75	-	Roller 00.6 006.100
7 x 11 x 7.75	-	Bush 00.6 006.200
7 x 17.5	-	Pin 00.6 006.300
		Washer 00.6 006.400

00.6 006.900



Reference Org. Part Nos. Roller Bush Pin VE-Pumps

Kit	-	148210-5720
Bosch	-	1 410 202 005 (148212-0000)
Bosch	-	1 410 300 052 (148211-0000)
Bosch	-	1 410 100 021 (148211-0000)
Washers	-	(148214-0000)
11 x 15 x 7.75	-	Roller 00.6 006.100
7 x 11 x 7.75	-	Bush 00.6 006.200
7 x 17.5	-	Pin 00.6 006.310 (Coated)
		Washer 00.6 006.400

ROLLERS

00.6 007.000 (6 007)

Roller & Pin VE



Kit 146701 0535

7 x 15 x 7.75	-	Roller	00.6 007.100
7 x 17.75	-	Pin	00.6 007.300
		Washer	00.6 007.400

00.6 007.900

Roller & Pin VE



Kit 146701 0536

7 x 15 x 7.75	-	Roller	00.6 007.100
7 x 17.75	-	Pin	00.6 007.310 (Coated)
		Washer	00.6 007.400

00.6 008.000 (6 008)

Feed Pump Roller & Pin



7 x 15 x 9	Roller	00.6 008.100	2 440 200 000
7 x 17.50 (flat face)	Pin	00.6 008.300	2 443 100 083

00.6 010.000 (6 010)

Feed Pump Roller & Pin 'P' Type



7 x 17 x 6.65-	Roller	00.6 010.100	- 2 440 103 002
			2 440 200 002
7 x 17.50	- Pin	00.6 010.300	- 2 443 100 015
			2 443 200 011

00.6 011.000 (6 011)

Tappet Roller Bush Pin Leyland - 680



14 x 20 x 12	-	Roller	00.6 011.100
9 x 14 x 12	-	Bush	00.6 011.200
9 x 28.50(with step)	-	Pin	00.6 011.300

ROLLERS

00.6 012.000 (6 012)



Tappet Roller Bush Pin (14mm)

14 x 20 x 12	- Roller	00.6 012.100
9 x 14 x 12	- Bush	00.6 012.200
9 x 27	- Pin	00.6 012.300

00.6 020.000



P Type

2 410 202 006
16 x 24 x 14.90
12 x 16 x 14.90
11.985 x 31.70

00.6 017.000 (6 017)



Simms

11 x 17 x 12	-	Roller	00.6 017.100
8 x 11 x 12	-	Bush	00.6 017.200
8 x 22.40	-	Pin	00.6 017.300

00.6 018.000 (6 018)



Feed Pump Roller for Feed Pump 00.1 017.000

7 x 15 x 5	Roller	00.6 018.100
7 x 10.8	Pin	00.6 018.300

00.6 019.000



11 x 17 x 9.9
7 x 11 x 9.9
6.985 x 25.8

00.6 021.000



Pin and Roller

Pin	: 7 X 21.90
Roller	: 7 X 17 X 11

Application

Leyland, Tata 407 & TC

00.6 022.000



Pin and Roller

Pin	: 7 X 21.50
Roller	: 7 X 15 X 9.90

Application

Tempo & Minidor

00.6 023.000



Pin and Roller

Pin	: 7 X 21.50
Roller	: 7 X 15 X 9.90

TAPPET ASSEMBLIES & BODIES

00.6100.020



**Tappet Assembly
'A' type for Inline Pump**
Reference Part Nos. : 1 418 720 020

00.6101.000



**Tappet Body
'A' type (9mm) for Inline Pump**

00.6110.023



**Tappet Assembly
'B' type for Inline Pump**
Reference Part Nos. : 1 418 720 023

00.6111.000



**Tappet Body 'B' type
(11mm) for Inline Pump**

01.7040.010



Tappet Bolt
Reference Part Nos. : 1 413 450 010

01.8020.010



Tappet Nut

01.9101.000



**Runner for Tappet Assy 'B' type
(for Inline Pump)**

00.6120.005



**Tappet Assy 'A' type
for Feed Pump**
Reference Org. Nos. - 2 447 010 005

00.6121.101



Tappet Body 'A' type for Feed Pump
Reference Org. Nos.
9 441 032 101, 2 442 120 011

00.6130.012



Tappet Assy 'P' type for Feed Pump
Reference Org. Nos.
2 447 010 012, 2 447 010 002

00.6131.000



Tappet Body 'P' type for Feed Pump
Reference Org. Nos.
2 442 120 013

BUSHES

00.6 200.000



Ref. No. : 1 460 400 004
Size : 17 x 21 x 15.25
VE SHAFT BUSH "A" SPLIT TYPE
(To be Reamed) Semi finished bore

00.6 201.000



Ref. No. : 1 460 400 014
Size : 20 x 24 x 15.25
VE SHAFT BUSH "B" SPLIT TYPE
(To be Reamed) Semi finished bore

00.6 201.100



VE SHAFT BUSH "B"
CLINTCH TYPE
(No Need to Ream)
Finished Bore size

00.6 205.000



Brass Bush
Size : 14x17.5x13.8

SPRINGS

00.6 300.010



Piston Spring for CI Feed Pumps

Reference Org. No. - 2 449 617 010

00.6 305.000



Piston Spring for Almn Feed Pumps

00.6 310.006



Feed Pump Valve Spring

Reference Org. No. - 2 444 615 006

00.6 320.001



Prefilter Spring

Reference Org. No. - 2 454 642 001

00.6 330.000



Circlip for Feed Pump Tappet Assy

Reference Org. No. - 2 444 601 000

00.6 342.000



Wire Dia	1.1mm
OD	9 mm
L	21.5 mm
Length with hook	36 mm

00.6 340.005



Double Hook Spring

Reference Org. No. - 1 424 650 005

Wire Dia	-	3.7 mm
Length	-	58 mm
OD	-	17.2 mm

00.6 343.000



Wire Dia	1.5 mm
OD	11 mm
L	19 mm
Length with hook	36 mm

00.6 341.000



Double Hook Spring (Starting Spring)

Wire Dia	-	0.6 mm
Length	-	32 mm
OD	-	10.5 mm

00.6 344.000



Wire Dia	1.1 mm
OD	10 mm
L	14.5 mm
Length With hook	32.5 mm

GASKETS

00.6 500.000



Feed Pump Gasket
Reference Part No.
1 411 073 000

00.6 510.047



**RSV Governor
Housing Packing Outer**
Reference Part No. :
1 421 415 047, 1 421 015 081

00.6 511.007



**RSV Governor
Housing Packing Inner**
Reference Part No. :
1 421 015 007, 2 421 015 054

00.6 512.000



RLD

00.6 513.000



00.6 517.000



00.6 514.000



Reference Part No. :
Delphi CAV - 485 1923
Thickness 0.80mm

00.6 515.000



00.6 516.000



00.6 520.000



Pump 6 Cylinder

00.6 521.000



Pump 8 Cylinder

00.6 525.000



Reference Part No.
RFD:9 421 612 152

00.6 526.000



00.6 527.000



RQV
Reference Part No.
Bosch : 1 421 015 061

00.6 528.022



Reference Org. Part Nos.
Bosch : 1 410 137 022
Thickness 0.50mm

00.6 529.110



Reference Org. Part Nos.
Bosch : 9 410 037 110
Thickness 0.50mm

00.6 530.190



Reference Org. Part Nos.
Bosch : 9 410 037 190
Thickness 0.50mm

00.6 531.021



Reference Org. Part Nos.
Bosch : 1 410 137 021
Thickness 0.50mm

00.6 532.002



Reference Org. Part Nos.
Bosch : 1 410 137 002
Thickness 0.50mm

00.6 533.000



Thickness 0.50mm

GASKETS

00.6 534.014



Reference Org. Part Nos.

Bosch : 2 421 015 014
Thickness 0.80mm

00.6 535.000



Reference Org. Part Nos.

Lucas : P89560
Thickness 0.50mm

00.6 537.000



Reference Org. Part Nos.

Lucas : 500361
Thickness 0.50mm

00.6 538.009

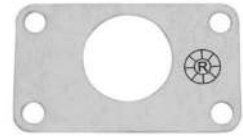

Reference Org. Part Nos.

Bosch : 2 421 039 009
Thickness 0.50mm

00.6 539.001



Reference Org. Part Nos.

Bosch : 1 410 051 001
Thickness 0.50mm

00.6 540.000



Reference Org. Part Nos.

Fiat : 764480
Thickness 0.50mm

00.6 541.000



Reference Org. Part Nos.

154352 0700
Thickness 0.50mm

00.6 542.000



Thickness 1.20mm

00.6 543.189



Reference Org. Part Nos.

Bosch : 9 410 037 189
Thickness 0.50mm

00.6 544.010



Reference Org. Part Nos.

Bosch : 1 410 137 010
Thickness 0.50mm

00.6 545.000



Reference Org. Part Nos.

NBR - Delphi
Thickness 1.60mm

00.6 546.000



Thickness 0.50mm

00.6 547.000



Thickness 0.50mm

00.6 548.008



Reference Org. Part Nos.

Bosch : 1 420 051 008
Thickness 0.50mm

00.6 549.006



Reference Org. Part Nos.

Bosch : 1 411 039 006
Thickness 0.50mm

00.6 550.000



Thickness 0.50mm

00.6 551.005



Reference Org. Part Nos.

Bosch : 2 420 051 005
Thickness 0.50mm

00.6 552.000



Reference Org. Part Nos.

Lucas CAV : 7139-70
Thickness 0.50mm

00.6 553.009



Reference Org. Part Nos.

Bosch : 1 420 051 009
Thickness 0.50mm

00.6 554.001



Reference Org. Part Nos.

Bosch : 2 421 074 001
Thickness 0.50mm

GASKETS

00.6 555.000



Thickness 0.50mm

00.6 556.000



Thickness 0.50mm

00.6 557.000



Thickness 0.50mm

00.6 558.119

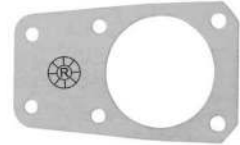

Reference Org. Part Nos.
Bosch : 9 410 037 119
Thickness 0.50mm

00.6 559.000



Thickness 0.50mm

00.6 560.015



VOLVO
Reference Org. Part Nos.
Bosch : 2421 015 015,
2421 015 074
Thickness 0.80mm

00.6 561.000



Thickness 0.50mm

00.6 562.000

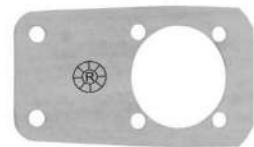

Thickness 0.50mm

00.6 563.005



Reference Org. Part Nos.
Bosch : 1 411 039 005
Thickness 0.50mm

00.6 564.000



Reference Org. Part Nos.
090823-0240
Thickness 0.50mm

00.6 565.058



Reference Org. Part Nos.
Bosch : 1 421 015 058
Thickness 0.50mm

00.6 566.000



Reference Org. Part Nos.
154352-3600
Thickness 0.50mm

00.6 568.000



Reference Org. Part Nos.
154350-7700
Thickness 0.50mm

00.6 569.000

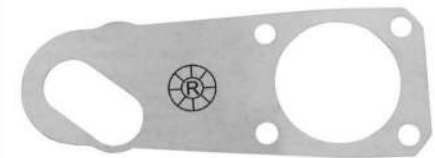

Thickness 0.50mm

00.6 570.019



Reference Org. Part Nos.
Bosch : 1 421 015 019
Thickness 0.50mm

00.6 571.000



Thickness 0.50mm

00.6 572.054



Reference Org. Part Nos.
Bosch : 1 421 015 054
Thickness 0.50mm

GASKETS

00.6 573.005



Reference Org. Part Nos.
Bosch : 1 411 039 005
Thickness 0.50mm

00.6 574.000



Reference Org. Part Nos.
Delphi CAV : 7180-450
Thickness 0.40mm

00.6 576.002



Reference Org. Part Nos.
Bosch : 1 410 137 002
Thickness 0.50mm

00.6 578.100



Reference Org. Part Nos.
Bosch : 3 421 015 100
Thickness 0.50mm

00.6 579.004



Reference Org. Part Nos.
Bosch : 9 421 037 004
Thickness 0.50mm

00.6 581.000



Thickness 0.50mm

00.6 583.000

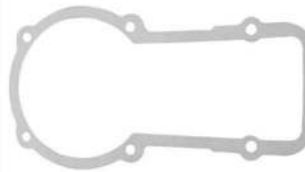

Thickness 0.50mm

00.6 584.000

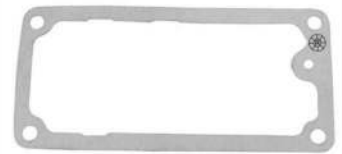

Reference Org. Part Nos.
Delphi CAV : 7123-515A
Thickness 0.80mm

00.6 585.071

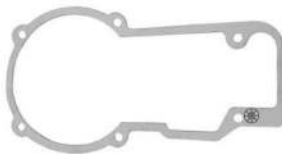

Reference Org. Part Nos.
Bosch : 1 421 015 071
Thickness 0.50mm

00.6 586.000



Reference Org. Part Nos.
Delphi CAV : 7123-287
Thickness 0.80mm

00.6 587.000



Thickness 0.80mm

00.6 588.000



Application - Simms
Thickness 0.50mm

00.6 589.000



Thickness 0.50mm
Gasket for Mack

00.6 590.000



Reference Org. Part Nos.
Simms : 501912
Thickness 0.50mm

00.6 592.000



Reference Org. Part Nos.
Bosch : 1 421 015 081
Thickness 0.50mm

00.6 594.000



Thickness 0.50mm

00.6 595.590



Reference Org. Part Nos.
Bosch : 9 400 023 590
Thickness 0.50mm

PLATE SUB ASSEMBLY

00.6 600.000



**ID 44, OD 94,
Thickness 0.5**
Set of 4 Pcs

00.6 601.000



ID 52, OD 110, Thickness 0.5
Set of 4 Pcs
RM 150 SCAB 15

00.6 602.000



ID 52, OD 110, Thickness 0.5
Same as 00.6601.000 but with rivets
Set of 4 Pcs

00.6 603.100



ID 48.10, OD 96.60, Thickness 0.50

00.6 604.100

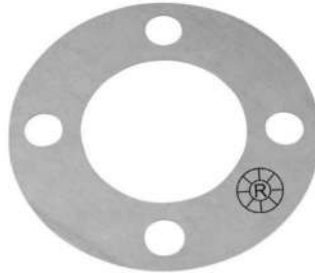

ID 65.20, OD 123.20, Hole OD 95
Thickness : 0.80

00.6 605.100



Application
DAF
Dimensions : OD 125.80, ID 66
Thickness : 0.6

00.6 606.000



Org. No. : 092460 0010
ID : 88.30
OD : 93.75 mm
Thickness : 0.50mm
No. of Plates : 5

00.6 607.000



95 X 95 X 0.5 (4 Pcs.)

00.6 608.000



95 X 95 X 0.5 (4 Pcs.)

PLATE SUB ASSEMBLY

00.6 609.000



Application :

Nissan Hino P11C, Nissan PF6TB

Dimension : ID 56, OD 128

Thickness : 0.5

Set of 6Pcs

OVER FLOW VALVES

00.8 000.010



Reference Org. Part Nos.

Bosch : 1 457 413 010

Application : Mercedes Benz, Tata O/M

Dimension: M 14x1.5 B-39.00, Hex 19.00 Turned

00.8 001.010

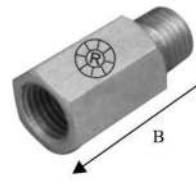

Reference Org. Part Nos.

Bosch : 1 457 413 010

Application: Mercedes Benz, Tata O/M

Dimension : M 14x1.5 B-39.00, Hex 19.00

00.8 001.600



Reference Org. Part Nos.

Bosch : 1 457 413 011 with Nylon Valve

00.8 002.032

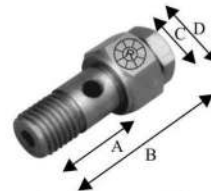

Reference Org. Part Nos. :
1 417 413 032

Dimension: Thread M 12 x 1.5, A-24, B-40.50, C-14, D-17, Bottom Hole 4mm

Application: Romania Z 2511, Fiat, Iveco, KHD, Lancia, Magirus Deutz.

00.8 003.047

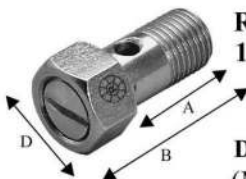

Reference Org. Part Nos.:
1 417 413 047

Dimension:
(M14 x 1.5, A-26, B-37, D-19, Bottom Hole 4mm)

Application : S Model, Mercedes, MAN, Magirus Deutz, Fiat, Lancia, MWM, Renault, New Holland, DAF, Fendt, IH, Iveco, KHD, MTU, VW

00.8 004.000

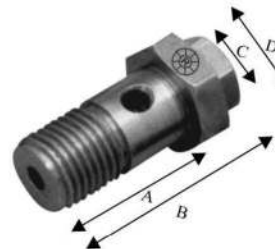

Reference Org. Part Nos.:
1 417 413 000 (PVE 74 S 2Z)

Dimension :
Thread M14x1.5, A-28, B-39.5, C-14, D-19, Bottom Hole 4mm

Application : Russian, Mercedes, Fiat, Lancia, Ford, Iveco, MWM Diesel, Renault, Opel, KHD, MTU, DAF, Dresser

00.8 005.046

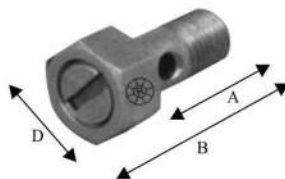

Reference Org. Part Nos. :
1 417 413 046

Dimension: M12x1.5, A -26, B-37, D-19, Bottom Hole 4mm

Application: Mercedes, MAN, Renault, Fiat, Lancia, MTU, MWM-Diesel

00.8 006.000

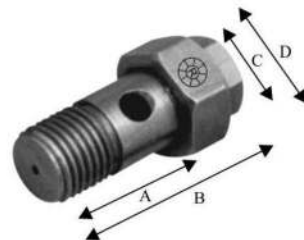

Dimension : Thread M14x1.5, A-26, B-40.5, C-14 Hex, D-19, Bottom Hole 1.5 mm

OVER FLOW VALVES

00.8 008.027

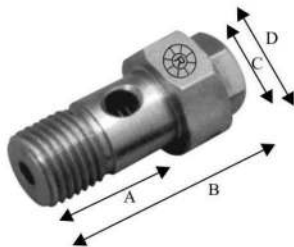

Reference Part Nos.
F 002 A 10627

Application : TC

Dimension : Thread M14x1.5, A-26, B-39.50, C-14 Hex, D-19, Bottom Hole 4 mm

00.8 009.000

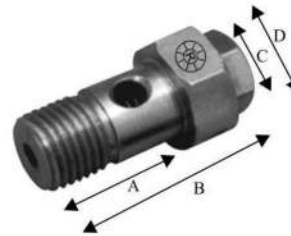

Application : T.C. Long

Dimension: Thread M 14x1.5 A -30, B-46, C-14 Hex, D-19 Hex, Bottom Hole – 4.50 mm

00.8 010.047

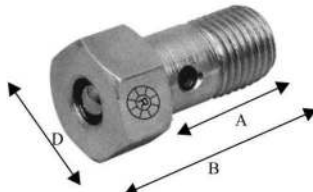

Reference Org. Part Nos.
Bosch : 1 417 413 047

Dimension: Thread M 14 x1.5 A -25.50, B-36.00, D-19 Hex, Bottom Hole - 4 mm

00.8 011.000

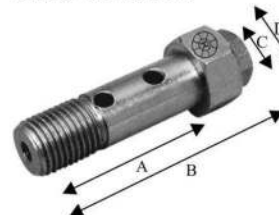

Ref. Part Org. Nos.:
BOSCH:F 002 A 10695
ZEXEL:134424 - 0820

Dimension : Thread M 14x1.5 A -45, B-61, C-14 Hex, D-19 Hex, Bottom Hole : 4.50

00.8 012.000

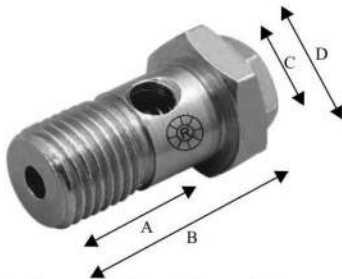

Reference Part Org. Nos. :

Dimension : Thread M14x1.5, A -26, B-37.00, C-14, D-19

00.8 014.000

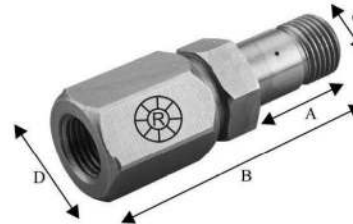

Reference Part Org. Nos. : 457 070 0246

Application : Merc. Actros

Dimension : Thread M16x1.5, A -28, B-70.50, C-22, D-24 Side hole : 1mm, Internal Thread M16 x 1.5

00.8 015.000 (00.8018.000)

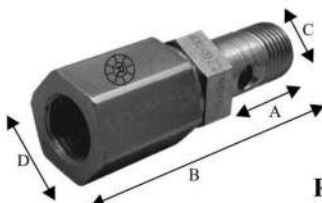

Reference Part Org. Nos. :
541 070 0646

Application : Merc. Actros

Dimension : Thread M16x1.5, A -28, B-70.50, C-22, D-24 Side hole : 6mm, Internal Thread : M16 x 1.5

00.8 016.000 (00.8031.000)

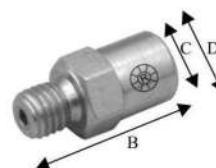

Application : Volvo FH 2043 0101

Dimension: Thread M10 x1.5, B-31, C-14.50, D-15 Hex
Bottom Hole : 3 mm
Internal Thread : M8 x 1.00
External Thread : M10 x 1.50

OVER FLOW VALVES

00.8 017.000

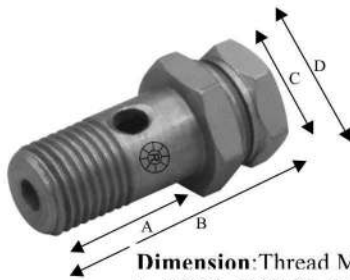

Dimension: Thread M14x1.5.
A -26.00, B-39.00, C-Hex 17,
D-Hex 19 Bottom Hole : 4.65 mm

00.8019.000



00.8 020.000

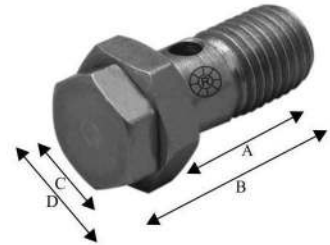

Dimension : Thread M14x1.5,
A -26, B-36.00, C-14, D-19
Bottom Hole : 4 mm

00.8 021.000

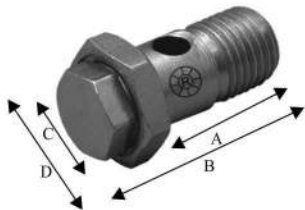

Dimension: Thread M12x1.5, A -24, B-35.00, C-14, D-17
Bottom Hole : 3.3 mm

00.8 023.000

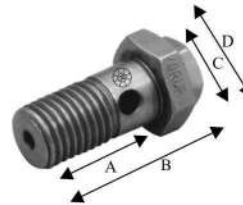

Dimension: Thread M12x1.5, A -24.30, B-33.50, C-Hex 12,
D-Hex 17, Bottom Hole : 3.30 mm

00.8 025.025

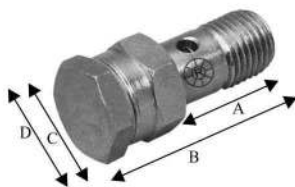

Reference Part Org. Nos.
Bosch : 1 417 413 025

Dimension : Thread M14x1.5, A -26, B-44.00, C-19 Hex,
D-19 Hex, Bottom Hole - 6.0 mm

00.8026.000



Dimension : Thread M14x1.5, A -28, B-42.50, C-Hex 17,
D-Hex 17 Bottom Hole : 4.50 mm

00.8027.000

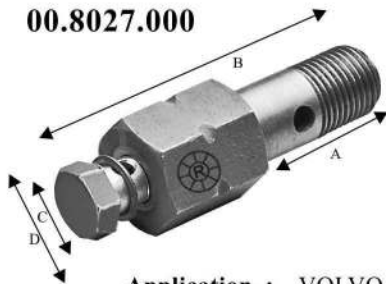

Application : VOLVO FH-12

Dimension : A-35, B-74, C-14, D-22 AF
Thread : M16 x 1.5
Bottom Hole : 4
Top Screw : M10 x 1, AF 14

00.8028.000

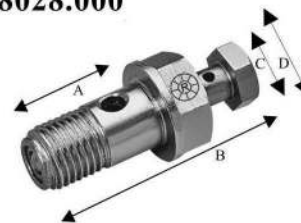

Dimension :
Thread M 14 x 1.50, A-27.5, B-50.00,
C-12 AF, D-19 AF,
Thread Length : 14.5
Top Bolt Length : 24 / 19
Top Bolt Thread : 8 x 1.25
Bottom Hole : 4.0

OVER FLOW VALVES

00.8029.000



Ref. Org. No. : 132 424 0620

Dimension : A-30, Thread : M14 x 1.5
Head A/F 19
Bolt Thread : 10 x 1
Bolt A/F 14

00.8030.000

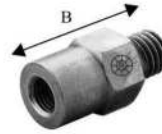

Dimension : B-29.00, Thread Size M 8 x 1.00
A / F 13 OD 12.25
Bottom Hole : 3.00 Internal
Thread : M8 x 1

00.8 032.000



Dimension : A 36.5, B 57.5 D 22.0
Internal Thread : M16x1.5
Application : Volvo

00.8 033.000



Dimension : A 36.5, B 57.5 D 22.0 AF
Internal Thread : M14x1.5
Application : Volvo

00.8 034.000



Dimension : B 24, D 17
Thread M10 x 1.5 and M10 x 1

00.8 035.000 (8 035)

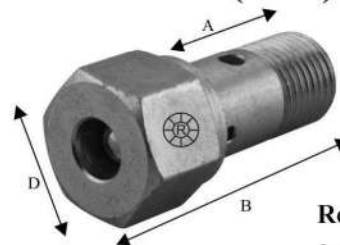

Dimension: A- 31, B-49, D-Hex 22
Thread : M16 x 1.5

Reference Part Org. Nos. :
2 469 403 747

00.8 036.000

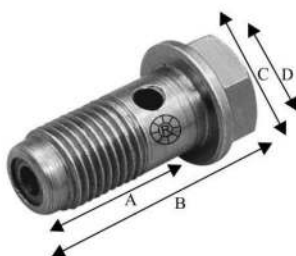

Dimension: Thread M14x1.5, A -30.50, B-39.50,
C (collar) - 21, D-Hex 17
Bottom Hole : 5.00 mm

00.8 037.000

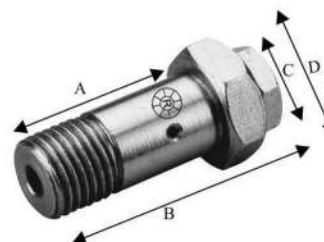

Dimension: A -31, B-43, C- 14, D-19, Side Hole 1.80

OVER FLOW VALVES

00.8013.000



Application HINO
 Ref.org. No. S 2210- 71760
 Dimension : Thread M
 14x1.5, A -45, B-81.50, C-14
 Hex D-22 Hex, Bottom Hole :
 5mm, Side Hole 3.50mm

00.8039.000



Dimension : A 29.50, B 56, D-Hex 22
 Internal And External Thread : M14 x 1.5
 Bottom Hole : 4.5mm
 Bar : 4
Application : Renault

00.8060.00



A-25

D-19 Hex

M 14 X 1.5

Pressure Set 8-22 Psi

Application : Cummins

00.8083.0

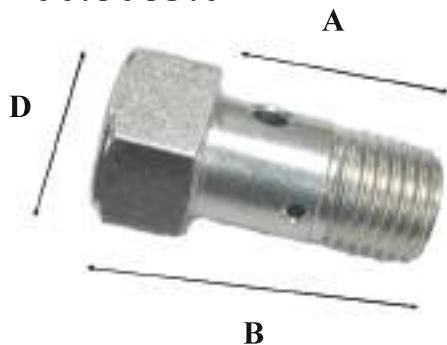

B - 36

A - 26

D - 19 A/F

Thread :- M14X1.5

OVER FLOW VALVES

00.8 040.000



Application Romania

Dimension Thread M27x1.5 A-40 B-50.3 C-24 D-31.95

00.8 050.000



Reference Part Org. Nos :
5410980057

Dimension Thread M8x1.5 B-53 D-19 Hex
Nipple OD 11.50 (for pipe ID 10)

00.8 054.000



Dimension A-20.5 B-28.75 D-40 AF
Bottom hole 3.5 Side hole 2.5
Thread M10 x 1

Washer 10 x 4 x 1
Volvo

00.8 055.000



Reference Part Org. Nos:
Ø9 5479
FH12VOLVO

Dimension Thread M6x1.5 A-49 B-55 D-22
Bottom Hole - 5

00.8 082.000



Similar to 0080 10000 But with 4 holes of 3mm each

00.8 092.000



Ref. Part Org. Nos.
Bosch 2 41 092 Z
Scania 1379215 609

Dimension Thread M6x1.5 B-47.50 D-22 A/F
Internal Thread M16 x 1.5

00.8093.000



APPLICATION
Iveco

Dimension Thread Size M16 x 1.5 A/F 22
Inner Thread Size: M14 x 1.5

00.8210.000



Suction Valve 8210

NON RETURN VALVES

00.8 306.060



**Inlet Pipe ID - 6mm
Outlet Pipe ID - 6mm**

00.8 308.080



**Inlet Pipe ID - 8mm
Outlet Pipe ID - 8mm**

00.8 310.100



**Inlet Pipe ID - 10mm
Outlet Pipe ID - 10mm**

00.8 312.120



**Inlet Pipe ID - 12mm
Outlet Pipe ID - 12mm**

00.8 350.000

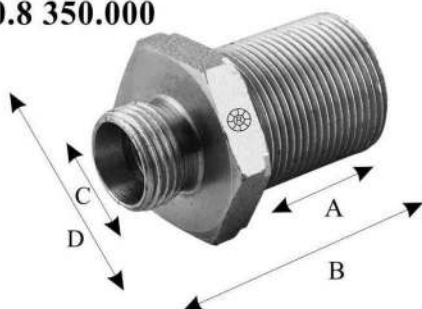

Reference Part No. : 8148327

**Dimension : A-30, B-48.3 C- M18X1.5 D-32.0 AF
Thread : M26 x1.5
with AC valve**

A.C. HAND PRIMER

00. 8408.000

For Pipe internal dia 8 mm



00. 8408.100

For Pipe internal dia 8 mm



00. 8410.000

For Pipe internal dia 10 mm



00. 8410.100

For Pipe internal dia 10 mm



00. 8412.000

For Pipe internal dia 12 mm



00. 8412.100

For Pipe internal dia 12 mm



A.C. VALVES & FEED PUMP VALVE

00.8 201.000



A.C. Valve with Rubber Seat

No.		OD
00.8 201.180	-	18mm
00.8 201.190	-	19mm
00.8 201.250	-	25.50mm

00.8 202.000



A.C. Valve with Nylon Seat

No.		OD
00.8 202.180	-	18mm
00.8 202.190	-	19mm
00.8 202.250	-	25.50mm

Feed Pump Valve



No.	Mat	Channels	Top	Colour
00.8 101.010	Nylon	1	Groove	Brown 2 443 203 001
00.8 101.020	Nylon	1	Groove	White 1 900 210 100
00.8 103.010	Nylon	3	Groove	Brown
00.8 103.020	Nylon	3	Groove	White 2 440 210 009
00.8 111.010	Bakelite	1	Groove	Brown
00.8 111.030	Bakelite	1	Groove	Cherry
00.8 111.110	Bakelite	1	Plain	Brown
00.8 111.130	Bakelite	1	Plain	Cherry
00.8 113.010	Bakelite	3	Groove	Brown 2 443 123 021
00.8 113.030	Bakelite	3	Groove	Cherry

Feed Pump Valve



Yanmar Type

No.	Mat	Channels	Top	Colour
00.8 301.120	Nylon	1	Plain	White
00.8 301.110	Nylon	1	Plain	Brown

Shaft Dia	-	6mm
Head Thickness	-	2.6mm

Nozzle Pressure Spindle

00.8810.000 Massey
 00.8811.000 Petter
 00.8812.000 Lister



Nozzle Pressure Spindle

00.8815.000 (C-335)
 00.8816.000 (Ford)
 00.8817.000 (E-37)



00.8818.000 (H-50)
 00.8819.000 (3511)
 00.8820.000 (2511)
 00.8821.000 (2011)

00.8350.000
 Non Return Valve DPC



00.8255.000
 Out Valve 0.55



00.8275.000
 Out Valve 0.75



PROFILED COPPER WASHERS

00.7 001.000



'U' Washer 6MM

ID OD Thickness GAP
Sizes : 6 x 10.5 x 1 x 7.3mm

00.7 002.000 'U' Washer 8MM



ID OD Thickness GAP
Sizes : 8 x 11.8 x 1 x 8.30mm
Reference Org. Part No. Mercedes : 352 078 0180
Application Mercedes : 352 / 355 / 402

00.7 002.010



'U' Washer

ID OD Thickness GAP
Sizes : 8 x 12.5 x 1 x 8.30mm
Reference Org. Part No.
 Mercedes : 352 078 0180
Application Mercedes : 352 / 355 / 402

00.7 002.020



'U' Washer

ID OD Thickness GAP
Sizes : 8 x 13.8 x 1 x 8.30mm
Reference Org. Part No. Mercedes : 352 078 0180
Application Mercedes : 352 / 355 / 402

00.7 003.000



'U' Washer

ID OD Thickness GAP
Sizes : 8 x 12 x 1 x 14.6mm

00.7 004.000



'U' Washer

ID OD Thickness GAP
Sizes : 8 x 12 x 1 x 10.8mm

00.7 011.000

Nozzle Washer Hino Small



ID OD Thickness GAP
Sizes : 9 x 20 x 1 x 5mm

00.7 012.000

Nozzle Washer Hino Med



ID OD Thickness GAP
Sizes : 9 x 21 x 1 x 6.2mm

00.7 013.000

Nozzle Washer Hino Big



ID OD Thickness GAP
Sizes : 9 x 22 x 1 x 7mm

00.7 015.000



ID OD Thickness
Sizes : 12 x 19.5 x 1 x 4 hole

00.7 016.000



ID OD Thickness
Sizes : 12 x 23 x 1 x 3 hole

00.7 017.000



ID OD Thickness
Sizes : 12 x 22.5 x 1 x 2 hole

ALUMINIUM WASHERS

00.7 301.140



Reference Org. Part Nos. - 093245-0140

Size : 12 x 19 x 1 x 2H

00.7 303.000



Size : 12 x 19x 1 x 4H

00.7 304.000



Size : 12 x 22 x 1 x Moon Type

00.7 305.000



Size : 12 x 19.5 x 1 x Moon Type

00.7 306.040



Reference Org. Part Nos. - 093245-0040

Size : 12.75 x 23 x 1 x 2H

00.7 307.000



Size : 12.75 x 23 x 1 x 3H

00.7 309.110



Reference Org. Part No. - 093245-0110

Size : 12.75 x 23 x 1 x Moon Type

00.7 311.000



Size : 13 x 22 x 1 x 2H

00.7 312.000



Size : 12.75 x 22 x 1 x 2H

00.7 320.000



Size : 15 x 25.5 x 1 x 4H

00.7 321.000



Size : 14 x 26.2 x 1 x 4H

HEAT SHIELDS

00.7112.400



SPECIFICATIONS						
ID	OD	TH	Material	Rajnish Nos.	Ref. Org. No.	Application
5.8	10.5	1.1	Steel	00.7112.400	03156258 0894420247-0	OPEL ISUZU MAZDA

00.7113.000



SPECIFICATIONS						
ID	OD	TH	Material	Rajnish Nos.	Ref. Org. No.	Application
9	14	1	Brass	00.7113.000	11177-56010 PAS 16354 75516354	TOYOTA 2L HI-LUX-LAND CRUISER NIPPON DENSO

00.7114.400



SPECIFICATIONS						
ID	OD	TH	Material	Rajnish Nos.	Ref. Org. No.	Application
7.8	11.2	1.5	Steel	00.7114.400	11177-64010 MD 0707185	TOYOTA 3L HI-LUX-1HZJ, LAND CRUISER NIPPON DENSO

00.7115.400



SPECIFICATIONS						
ID	OD	TH	Material	Rajnish Nos.	Ref. Org. No.	Application
10	14	1.5	Steel	00.7115.400		

00.7116.400



7.50 X 14.30
Profile Height : 1.60

00.7134.xxx



SPECIFICATIONS						
ID	OD	TH	Material	Rajnish Nos.	Ref. Org. No.	Application
7.5	20.1	2.8	Brass Copperised / Brass Copper	00.7134.000 00.7134.100 00.7134.200	2 430 501 006 6140095 84FF9M577AC	FORD, ESCORD-FIESTA, MONDEO-SIERA ORION

00.7135.xxx



SPECIFICATIONS						
ID	OD	TH	Material	Rajnish Nos.	Ref. Org. No.	Application
10	16	4.5	Brass Copperised / Brass Copper	00.7135.000 00.7135.100 00.7135.200	Me001017	MITSUBISHI

00.7136.xxx



SPECIFICATIONS						
ID	OD	TH	Material	Rajnish Nos.	Ref. Org. No.	Application
11	18	4.5	Brass Copperised / Brass Copper	00.7136.000 00.7136.100 00.7136.200	30003-10306	TOYOTA

00.7137.xxx



SPECIFICATIONS						
ID	OD	TH	Material	Rajnish Nos.	Ref. Org. No.	Application
10.85	17.5	6	Brass Copperised / Brass Copper	00.7137.000 00.7137.100 00.7137.200	082131	ISUZU ENGINE OPEL CORSA

00.7138.xxx



SPECIFICATIONS						
ID	OD	TH	Material	Rajnish Nos.	Ref. Org. No.	Application
9.45	19	7.6	Brass Copperised / Brass Copper	00.7138.000 00.7138.100 00.7138.200	15315-0030 1205870	ISUZU

HEAT SHIELDS

00.7139.xxx



SPECIFICATIONS						
ID	OD	TH	Material	Rajnish Nos.	Ref. Org. No.	Application
7.45	21.7	3.8	Brass	00.7139.000	11176-87301	DAIHATSU

00.7140.xxx



SPECIFICATIONS						
ID	OD	TH	Material	Rajnish Nos.	Ref. Org. No.	Application
7.2	14	4.7	Brass Copperised / Brass Copper	00.7140.000 00.7140.100 00.7140.200	16539	ISUZU MEO

00.7141.xxx



SPECIFICATIONS						
ID	OD	TH	Material	Rajnish Nos.	Ref. Org. No.	Application
7.1	14	4	Brass Copperised / Brass Copper	00.7141.000 00.7141.100 00.7141.200	620411-3880 MEO16539	TOYOTA ISUZU KOMATSU

00.7142.xxx



SPECIFICATIONS						
ID	OD	TH	Material	Rajnish Nos.	Ref. Org. No.	Application
7.3	15	6.5	Brass Copperised / Brass Copper	00.7142.000 00.7142.100 00.7142.200	894125-3880	TOYOTA ISUZU

00.7143.000



SPECIFICATIONS						
ID	OD	TH	Material	Rajnish Nos.	Ref. Org. No.	Application
15	21.5	3	Brass	00.7143.000	11176-56010 11176-77010	TOYOTA

00.7144.000



SPECIFICATIONS						
ID	OD	TH	Material	Rajnish Nos.	Ref. Org. No.	Application
12	18	2.5	Brass	00.7144.000	11176-64010	TOYOTA

00.7145.000



SPECIFICATIONS						
ID	OD	TH	Material	Rajnish Nos.	Ref. Org. No.	Application
14.5	20	3	Brass	00.7145.000	11760-36010	TOYOTA

00.7146.000



SPECIFICATIONS						
ID	OD	TH	Material	Rajnish Nos.	Ref. Org. No.	Application
7.5	17	2.5	Brass	00.7146.000	11165-56020	TOYOTA

HEAT SHIELDS

00.7147.000



SPECIFICATIONS						
ID	OD	TH	Material	Rajnish Nos.	Ref. Org. No.	Application
7.5	17	2	Brass	00.7147.000	11176-56030	MITSUBISHI

00.7148.000



SPECIFICATIONS						
ID	OD	TH	Material	Rajnish Nos.	Ref. Org. No.	Application
11.2	18	2.6	Brass	00.7148.000		Brass

00.7149.xxx



SPECIFICATIONS						
ID	OD	TH	Material	Rajnish Nos.	Ref. Org. No.	Application
9.2	19	7.3	Brass Copperised / Brass Copper	00.7149.000 00.7149.100 00.7149.200		

00.7150.xxx



SPECIFICATIONS						
ID	OD	TH	Material	Rajnish Nos.	Ref. Org. No.	Application
14.5	21.5	3.3	Brass	00.7150.000		

00.7151.000



SPECIFICATIONS						
ID	OD	TH	Material	Rajnish Nos.	Ref. Org. No.	Application
14.2	20	3	Brass	00.7151.000		

00.7152.xxx



SPECIFICATIONS						
ID	OD	TH	Material	Rajnish Nos.	Ref. Org. No.	Application
7.1	21.2	4.2	Brass Copperised / Brass Copper	00.7152.000 00.7152.100 00.7152.200		

00.7153.000



SPECIFICATIONS						
ID	OD	TH	Material	Rajnish Nos.	Ref. Org. No.	Application
11	17.5	5.4	Brass	00.7153.000		

00.7154.000



SPECIFICATIONS						
ID	OD	TH	Material	Rajnish Nos.	Ref. Org. No.	Application
7.7	17	3.5	Brass	00.7154.000		

HEAT SHIELDS

00.7155.000



SPECIFICATIONS						
ID	OD	TH	Material	Rajnish Nos.	Ref. Org. No.	Application
10	16	4.25	Brass	00.7155.000		

00.7156.xxx



SPECIFICATIONS						
ID	OD	TH	Material	Rajnish Nos.	Ref. Org. No.	Application
10	16	4.2	Brass Copperised / Brass Copper	00.7156.000 00.7156.100 00.7156.200		

00.7157.200



SPECIFICATIONS						
ID	OD	TH	Material	Rajnish Nos.	Ref. Org. No.	Application
7	16	2	Copper	00.7157.200		TOYOTA SR NOZZLE WASHER

00.7158.000



SPECIFICATIONS						
ID	OD	TH	Material	Rajnish Nos.	Ref. Org. No.	Application
14.5	22	3	Brass	00.7158.000		

00.7159.xxx



SPECIFICATIONS						
ID	OD	TH	Material	Rajnish Nos.	Ref. Org. No.	Application
9.5	16	4.5	Brass Copperised / Brass Copper	00.7159.000 00.7159.100 00.7159.200		

00.7160.400



SPECIFICATIONS						
ID	OD	TH	Material	Rajnish Nos.	Ref. Org. No.	Application
8	25	3	Steel Copperised	00.7160.400		TOYOTA DA

00.7161.049



Application : Merc. Actros
Ref. Bosch No. : 2 430 105 049

00.7162.000



ID OD TH
7.3 X 16.30 X 1.80

D.V. WASHERS & JOINTS

00.7 401.200



Reference Org Part Nos. - 13 1115-1200
Size : 8x16x0.5

00.7 402.000



Reference Org Part Nos. - 13 1115-1600 (NISSAN)
Size : 8x14x0.5x1.5

00.7 403.101



Reference Org Part Nos. - 1 410 500 101 (HINO)
Size : 9.4x14x0.5x1.5

00.7 404.110



Reference Org Part Nos. - 090137-0110
Size : 9.7x14x0.5

00.7 405.550



Reference Org Part Nos. - 090137-0550
Size : 13x17x0.7

00.7 406.000



Reference Org Part Nos. - 2410-105003
Size : 11.7x18x0.5

00.7 407.000



Size : 9.7x13x0.5

00.7 450.020



D.V. Joint

Reference Org Part Nos. : 1 410 206 020 ('A' type)
Size : 12.30x17.60x3
Material : Plastic (Nylon)

00.7 451.022



D.V. Joint

Reference Org Part Nos. : 1 410 206 022 ('B' type)
Size : 12.2x17x3
Material : Plastic (Nylon)

00.7 452.023



D.V. Joint

Reference Org Part Nos. : 1 426 206 023 (CAV type)
Size : 12x16x3
Material : Plastic (Nylon)

00.7 453.010



Reference Org Part Nos. : 090137-00100

Size : 12x18x3

NOZZLE CAP NUTS

00.7850.000

Nozzle Cap Petter
Swaraj 855



OD: 24.50 MM
Length : 42.00 MM
Thread : M20 X 1.50

00.7851.000

Nozzle Cap Lister, P3 Massey



OD: 24.50 MM
Length : 25.00 MM
Thread : M20 X 1.50

00.7852.000

Nozzle Cap Inter DI



OD: 20.75 MM
Length: 47.50 MM
Thread : M19 X 0.75

00.7853.000

Nozzle Cap Ford, Swaraj FE



OD: 21.25MM
Length : 50 MM
Thread : 3/4 x 16 TPI

00.7854.000

Nozzle Cap Cargo



OD: 21.00 MM
Length: 46.20 MM
Thread: M19 X 0.75

00.7855.000

Nozzle Cap T.C.



OD: 16.90 MM
Length : 31.20 MM
Thread : M15 X 0.50

00.7856.000

Nozzle Cap Kirloskar



AF: 16.80 ID: MM
Length : 30.70 |
Thread : M22 X

00.7857.000

Nozzle Cap L/L 402



OD: 24.50 MM
Length : 54 MM
Thread : M22 X 1.5

00.7858.000



Application : Romania
OD: 25 MM
Length : 35 MM
Thread : M22 X 1.5

00.7859.000



Application : Romania
OD: 21.40MM
Length: 43.50 MM
Thread : M19 X 1.25

00.7865.000



Application : ISUZU
OD: 16.SOMM
Length : 31.20 MM
Thread : M15 X 0.50

00.7881.000



Application : Mitsubishi
OD : 21.40MM Length : 35.SOMM
Internal Thread : M16 X 1
External Thread : M20 X 1.5

00.7882.000

(Old No.00.8041.00)

Application :
Mitsubishi



Ref. Part No. :
093164-1351

OD: 21.SOMM, Length : 35.SOMM
Internal Thread: M16 X 0.75
External Thread : M20 X 1.5

00.7898.000

Automiser Connection



B+B
AF=14MM
LENGTH=46MM

00.7899.000

Automiser Connection



B+B
AF=14MM
LE GTH=37MM

00.7897.000

Automiser Connection



A+B
AF=14MM
LE GTH=37MM

Automiser Connection



00.7894.000 Minidor
00.7895.000 Tempo
00.7896.000 APE

SHIMS FOR COMMON RAIL INJECTORS

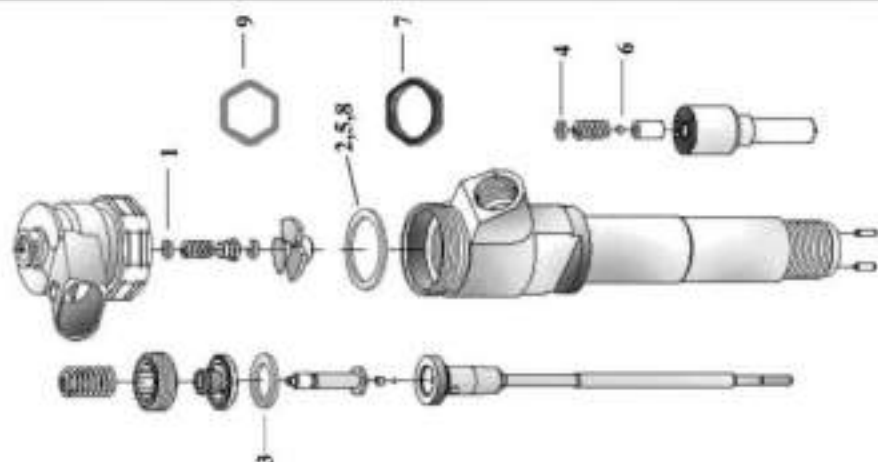

1	2	3	4	5	6	7	8	9
SOLENOID SPRING SHIM 00.7550.000	AIRGAP SHIM 00.7555.000	CR1 BALL LIFT SHIM 00.7560.000	NOZZLE SPRING SHIM FOR BOSCH, DENSO, SIEMENS (3.5X5.3 MM) 00.7585.000	DENSO MAIN SHIM 00.7580.000	DGV SHIM 00.7570.000	CRIN HEX BALL LIFT SHIM 00.7561.000	CRIN 2 ROUND BALL LIFT SHIM (19.6X22.8 MM) 00.7562.000	SIEMENS HEX AIRGAP SHIM 00.7563.000
1.15	0.90	1.15	1.05	1.50	1.04	0.95	1.50	0.91
1.20	0.91	1.16	1.10	1.51	1.06	0.96	1.51	0.92
1.25	0.92	1.17	1.15	1.52	1.08	0.97	1.52	0.93
1.30	0.93	1.18	1.20	1.53	1.10	0.98	1.53	0.94
1.35	0.94	1.19	1.25	1.54	1.12	0.99	1.54	0.95
1.40	0.95	1.20	1.30	1.55		1.00	1.55	0.96
1.45	0.96	1.21	1.35	1.56	1.16	1.01	1.56	0.97
1.50	0.97	1.22	1.40	1.57	1.18	1.02	1.57	0.98
1.55	0.98	1.23	1.45	1.58	1.20	1.03	1.58	0.99
1.60	0.99	1.24	1.50	1.59	1.22	1.04	1.59	1.00
1.65	1.00	1.25	1.55	1.60	1.24	1.05	1.60	1.01
1.70	1.01	1.26	1.60	1.61	1.26	1.06	1.61	1.02
1.75	1.02	1.27	1.65	1.62	1.28	1.07	1.62	
1.80	1.03	1.28	1.70	1.63	1.30	1.08	1.63	
1.85	1.04	1.29	1.75	1.64	1.32	1.09	1.64	
1.90	1.05	1.30	1.80	1.65	1.34	1.10	1.65	
1.95	1.06	1.31	1.85	1.66	1.36	1.11	1.66	
2.00	1.07		1.90	1.67	1.38	1.12	1.67	
2.05	1.08		1.95	1.68	1.40	1.13	1.68	
2.10	1.09		2.00	1.69	1.42	1.14	1.69	
2.15	1.10		2.05	1.70	1.44	1.15	1.70	
2.20	1.11		2.10	1.71	1.46	1.16	1.71	
2.25	1.12		2.15	1.72	1.48	1.17	1.72	
2.30	1.13		2.20		1.50	1.18	1.73	
	1.14		2.25			1.20		
	1.15		2.30			1.22		
	1.16					1.24		
	1.17					1.26		
	1.18					1.28		
	1.19					1.30		
	1.20					1.32		
	1.21					1.34		
	1.22					1.36		
	1.23					1.38		
	1.24					1.40		
	1.25					1.42		

PLASTIC COMPARTMENT BOXES



COMPARTMENTS :
128 Small, 16 Medium & 9 Large
Wall Hanging



COMPARTMENTS : 256 Small
Wall Hanging



COMPARTMENTS : 34 Small (17+17)

CR CAP NUT



Cap Nuts

<p>00.7800.155 HARD STEEL</p>  <p>Bosch Type F 00V C14 010 M15X0.5, L31.20</p>	<p>00.7801.175 HARD STEEL</p>  <p>Bosch Type HV M17X0.5, L35</p>	<p>00.7802.175 HARD STEEL</p>  <p>Bosch Type TTR M17X0.75, L35</p>	<p>00.7820.155 HARD STEEL</p>  <p>Delphi Type M15X0.5, L41</p>	<p>00.7830.175 HARD STEEL</p>  <p>Denso Type M17X0.5, L42.50</p>	<p>00.7835 HARD STEEL</p>  <p>Siemens / Vdo Type</p>
--	--	--	--	--	--

Copper Heat Shields

<p>Heat Shield SM</p> <p>7.5 X 17 X 2.5</p>  <p>00.7146</p>	<p>Heat Shield DNI</p> <p>7.5 X 16 X 1.80 X TAPER EDGE</p>  <p>00.7157</p>	<p>Heat Shield 20I</p> <p>7.3 X 12.6 X 2</p>  <p>00.7165</p>	<p>Heat Shield</p> <p>3 SLOT, Thickness-2.5mm OD-16mm</p>  <p>00.7171</p>	<p>Heat Shield FEND OE TYPE</p> <p>3 SLOT, Thickness-2mm OD-16mm</p>  <p>00.7174</p>	<p>Heat Shield FEND</p> <p>3 SLOT, Thickness-1.5mm OD-16mm</p>  <p>00.7173</p>
<p>Heat Shield NIMI</p> <p>4 SLOT, Thickness-3mm OD-15mm</p>  <p>00.7176</p>	<p>Heat Shield FF</p> <p>4 SLOT, Thickness - 2.5mm OD-15mm</p>  <p>00.7177</p>	<p>Heat Shield</p> <p>4 SLOT, Thickness - 2.0mm OD-15mm</p>  <p>00.7180</p>	<p>Heat Shield SSW</p> <p>4 SLOT, Thickness - 1.5mm OD-15mm</p>  <p>00.7181</p>	<p>Heat Shield MSR</p> <p>4 SLOT, Thickness - 2mm OD-13mm</p>  <p>00.7178</p>	<p>Heat Shield SKL</p> <p>4 SLOT, Thickness-1.5mm OD-13mm</p>  <p>00.7182</p>
<p>Heat Shield INV</p> <p>8 X 13 X 1 X 12 GAP</p>  <p>00.7005</p>	<p>Heat Shield Steel</p> <p>8 X 15 X 1 X 10 GAP</p>  <p>00.7006</p>	<p>Heat Shield Steel</p> <p>9 X 15 X 1 X 20 GAP</p>  <p>00.7007</p>	<p>Return Line Kit</p>  <p>DT660020 LB7 Install Kit</p>	<p>Heat Shield ACTROS</p>  <p>00.7161.049 2 430 105 049</p>	<p>Heat Shield</p> <p>Thickness 1.5 mm OD-14.90, 4 SLOT</p>  <p>Ref Org No- F OOR J01 453</p>

DIESEL FILTER COVERS & ASSEMBLIES

00.9 072.000



Size : 0.5 L
Reference Part Nos.
 Mico. : 1 455 526 072
Direction
 Micro ← Pre
 O/Valve - Right

00.9 100.000



Size : 0.5 L
Reference Part Nos.
 Mico. : 9 450 030 100
Direction
 Micro ← Pre
 O/Valve - Right

00.9 074.000



Size : 0.5 L
Reference Part Nos.
 Mico. : 1 455 526 074
Direction
 Pre → Micro

00.9 074.111



Size : 0.5 L
Direction
 Pre → Micro
 No Airvent screw on left side

00.9 117L.111



Size : 0.5 L
Direction
 Pre → Micro
 No Airvent screw on left side

00.9 532.000



Size : 1.00 L
Reference Part Nos.
 Bosch : 9 451 035 532
 Merc. : 000 477 3508
Direction
 Pre → Micro
 with adopter
Application
 TATA DI, Merc. OM 355

00.9 029.000



Size : 1.00 L
Reference Part Nos.
 Bosch : 0 450 226 029
 Merc. : 422 090 0252
Direction
 Pre → Micro
 with adopter

Application
 TATA DI, Merc. OM 355

DIESEL FILTER COVERS & ASSEMBLIES

00.9 558.000



Mere. : 9 451 035 558
 Mere. : 000 477 3708

Inlet - Right
 Micro — Pre

Application

Diesel Filter Cover
 Leyland, Mere. OM 346

00.9 028.000



Size : 1.00 L
 Reference Part Nos.
 Bosch : 0 450 226 028
 Mere. : 001477480

Inlet - Right
 Micro — Pre

Application

Diesel Filter Assembly
 Leyland, Mere. OM 346

00.9300.000



00.9250.000

Filter Cover - Volvo 81 94 541

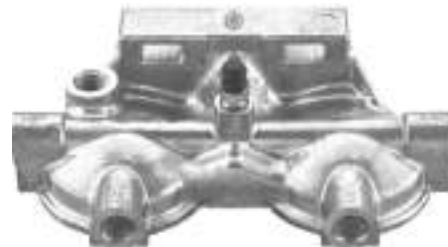

00.9251.000



Application : Diesel Filtercover
 Scania 112/ 113
 Reforg.No.0357196.525356

DIESEL FILTER COVERS & ASSEMBLIES

00.9 111.000



BOWL

Size : 1.0 L

Reference Part Nos.

Mico : 9 451 035 111

Merc. : 422 090 007

00.9 101.000



BOWL

Size : 0.5 L

Reference Part Nos.

Mico : 9 451 035 101

MISC PARTS OF DIESEL FILTER ASSEMBLIES

01.7010.261



Filter Bolt

Reference Part Nos. : 2 911 161 261

00.4722.042



Rubber washer for 0.5 L

Reference Part Nos. : 1 450 109 042

00.4723.001



Rubber washer for 1.00 L

Reference Part Nos. : 1 450 109 001

DIESEL FILTER COVER CAV TYPES

00.9 010.000

Filter Cover



Inlet / Outlet : M14x1.5
Top Hole Thread : M10x1.5

00.9 010.100

Filter Cover



Inlet / Outlet : 1/2" x 20 UNF
Top Hole Thread M10 x 1.5

00.9 011.000

Filter Cover



Inlet / Outlet : M14 x 1.5
Top Hole Thread : M10 x 1.5
with Air Vent screw

00.9 011.100

Filter Cover



Inlet / Outlet : 1/2" x 20 UNF
Top Hole Thread M10 x 1.5
with Air Vent Screw

00.9 021.000

Filter Assembly



Cover : 00.9011.000
(M14 x 1.5)
Bowl : 00.4550.000

00.9 021.100

Filter Assembly



Cover : 00.9011.100
(1/2" x 20 UNF)
Bowl : 00.4550.000

00.9 022.000

Filter Assembly



Cover : 00.9011.000
(M14 x 1.5)
Bowl : 00.4551.000

00.9 022.100

Filter Assembly



Cover : 00.9011.100
(1/2" x 20 UNF)
Bowl : 00.4551.000

00.9 015.000



Thread M14 x 1.5

00.9 019.000



Thread M14 x 1.5

00.9 015.100



Thread : 1/2" x 20 UNF

00.9 019.100



Thread : 1/2" x 20 UNF

INSPECTION PLATES

00.9 102.000 (9 102)

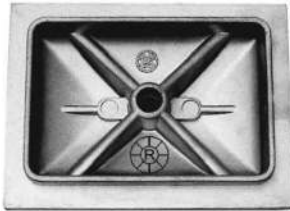

Application : P2

Repl. No. 9 415 622 102

00.9 112.000 (9 112)



Application : P3

Repl. No. 9 411 035 612

00.9 105.000 (9 105)



Application : P4

Repl. No. 1 415 624 105

00.9 114.000 (9 114)



Application : P6

Repl. No. 1 415 626 114

OBEN TOP PLATE

00.9 014.000 (9 014)



Repl. No. 1421060014

BANJO TEES

3 Step type



ID(mm)	Pipe Internal Dia (mm)	Rajnish Part Nos.
6	4	01.1006.040
8	4	01.1008.040
8	6	01.1008.060
10	4	01.1010.040
10	6	01.1010.060
10	8	01.1010.080
10	10	01.1010.100
12	4	01.1012.040
12	6	01.1012.060
12	8	01.1012.080
1/2"	5/16"	01.1012.087
12	10	01.1012.100
1/2"	3/8"	01.1012.107
13	8	01.1013.080
13	10	01.1013.100
14	4	01.1014.040
14	6	01.1014.060
14	8	01.1014.080
14	9	01.1014.090
14	10	01.1014.100
14	12	01.1014.120
16	8	01.1016.080
16	9	01.1016.090
16	10	01.1016.100
16	12	01.1016.120

Note: The O.D. of the step is 1-1.5mm more than the Pipe Internal Dia

Single step type



ID(mm)	Pipe Internal Dia (mm)	Rajnish Part Nos.
8	5	01.1108.050
8	7	01.1108.070
10	5	01.1110.050
10	7	01.1110.070
10	9	01.1110.090
12	8	01.1112.080
12	10	01.1112.100
14	6	01.1114.060
14	7	01.1114.070
14	8	01.1114.080
14	9	01.1114.090
14	10	01.1114.100
16	10	01.1116.100

Note : The O.D. of the step is 1-1.5mm more than the Pipe Internal Dia

Plain type small



ID(mm)	Pipe External Dia(mm)	Rajnish Part Nos	Reference Part Nos.
8	4	01.1208.040	1 903 385 003
8	6	01.1208.060	
10	6	01.1210.060	1 903 385 035
10	8	01.1210.080	1 903 385 007
12	8	01.1212.080	
14	10	01.1214.100	1 903 385 009
16	10	01.1216.100	
18	10	01.1218.100	
18	15	01.1218.150	1 903 385 013
20	10	01.1220.100	
22	10	01.1222.100	

3 Step type two way



Size(mm)	Pipe Internal Dia(mm)	Rajnish Part Nos
6	4	01.1406.040
6	6	01.1406.060
8	4	01.1408.040
8	6	01.1408.060
10	4	01.1410.040
10	6	01.1410.060
10	8	01.1410.080

Note : The O.D. of the step is 1-1.5mm more than the Pipe Internal Dia

Single step type two way



Size(mm)	Pipe Internal Dia(mm)	Rajnish Part Nos
8	5	01.1508.050
8	7	01.1508.070
10	5	01.1510.050
10	7	01.1510.070

Note : The O.D. of the step is 1-1.5mm more than the Pipe Internal Dia

BANJO BOLTS

Banjo Bolt Single Banjo type



Thread Size	Shaft Length	Head A/F	Part No.	Ref. Org. No.
OD x Pitch x Length				
M 6 x 1.00 x 8.00	14mm	10.00	01.5006.100	
M 8 x 0.75 x 9.00	16mm	12.00	01.5008.750	
M 8 x 1.00 x 9.00	17.50mm	12.00	01.5008.100	2 911 222 700
M 8 x 1.25 x 9.00	17.50mm	12.00	01.5008.125	
M 10 x 1.00 x 10.00	19.50mm	14.00	01.5010.100	2 911 201 701
M 10 x 1.25 x 10.00			01.5010.125	
M 10 x 1.50 x 10.00	19.50mm	14.00	01.5010.150	
M 12 x 1.00 x 13.50	24mm	17.00	01.5012.100	
M 12 x 1.25 x 13.50	24mm	17.00	01.5012.125	
M 12 x 1.50 x 13.50	24mm	17.00	01.5012.150	2 911 201 702
M 14 x 1.50 x 13.00	26mm	19.00	01.5014.150	2 911 201 703 9 411 033 404 915011 008 101
M 16 x 1.50 x 15.00	30mm	22.00	01.5016.150	2 911 201 705 915011 01 01 02
M 18 x 1.50			01.5018.150	2 911 202 705

Banjo Bolt Double Banjo type



Thread Size	Shaft Length	Head A/F	Part No.	Ref. Org. No.
OD x Pitch x Length				
M 8 x 1	26mm	12.00	01.5108.100	
M 14 x 1.50 x 13.00	40mm	19.00	01.5114.150	915 011 008 102
M 16 x 1.50 x 15.00	46mm	22.00	01.5116.150	915 047 012 200

Banjo Bolt with Wire Filter



Thread Size	Shaft Length	Head A/F	Part No.
OD x Pitch x Length			
M 14 x 1.5 x 13.00	27mm	19.00	01.5114.160

Banjo Bolt with Filter Zexel type



Thread Size	Shaft Length	Head A/F	Part No.
OD x Pitch x Length			
M 14 x 1.5 x 13.00	27mm	17.00	01.5214.160

Repl. Diesel Kiki No. - 152300 - 0920

Without Filter - 01.5214.150

BANJO BOLTS

Banjo Bolt with Filter Denso type



Thread Size	Shaft Length	Head A/F	Part No.
M 14 x 1.5			01.5914.160

Without Filter - 01.5914.150

Banjo Bolt Denso Type



Thread Size	Shaft Length	Head A/F	Part No.
M 14 x 1.5	26mm	22mm	01.6214.150

00.4403.003

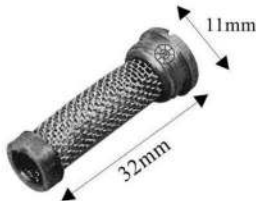

Brass Filter for Banjo Bolt
Bosch No. - 2 440 401 003

Angle Adopter



Thread Size	Bore	Part No.
OD x Pitch x Length		
M 16 x 1.5 x 16.00	16mm	01.6016.150

Flat Adopter



Thread Size	Bore	Part No.
OD x Pitch x Length		
M 16 x 1.5	16mm	01.6116.150

Banjo Bolt Small with 4 holes



Thread Size	Shaft Length	Head A/F	Part No.
OD x Pitch x Length			
M 12 x 1.50 x 12.00	25mm	17.00	01.5312.150
M 14 x 1.50	25mm		01.5314.150

Banjo Bolt Long with 4 holes



Thread Size	Shaft Length	Head A/F	Part No.
OD x Pitch x Length			
M 16 x 1.5			01.5416.150
M 18 x 1.5			01.5418.150

BANJO BOLTS

Banjo Bolt Step type



Thread Size	Shaft Length	Head A/F	Part No.	Step Length	Step Dia
OD x Pitch x Length					
M 8 x 1.00 x 8.00	14.60	12.00	01.5508.100	3.00	6.50
M 11 x 1.25 x 13.50	23	19.00	01.5511.125	3.00	12.85
M 8 x 0.75 x 65	14.25	11.00	01.5508.075	3.00	7.85
M 6 x 1.0 x 9	14.90	10.00	01.5506.100	3.00	5.85

Banjo Bolt Long with Filter ND type



Thread Size	Shaft Length	Head A/F	Part No.	Step Length	Step Dia
OD x Pitch x Length					
M 14 x 1.50 x 11	26.00	19.00	01.5614.160 01.5614.150 without filter	30.00	18.80

01.5716.150



For Feed Pump 00.1 056.100

Banjo Bolt with 3 Holes



Thread Size	Shaft Length	Head A/F	Part No.
OD x Pitch x Length			
M12 x 1.5 x 13.00	24	17	01.5812.150
M14 x 1.5 x 13.00	26	19	01.5814.150
M18 x 1.5			01.5818.150
M14 x 1.5			01.5816.150

01.6314.150 Banjo Bolt with 1.66 mm Side Hole



A-26
B-33.5
D-19 HEX
Side Hole-1.66 mm

01.6412.150



A-26
B-41
D-14.5 Hex
C-17.25
M-12X1.5

SPECIAL BOLTS

01.7 001.001



Stud Bolt
Reference Org. No. 2 453 405 001

01.7 010.261



Filter Bolt
Reference Org. No. 2 911 161 261

01.7 015.000



Hardware Set for CAV filter

01.7 016.000



Bolt for 00.4555.000 Bowl

01.7 030.024



Centre Bolt
Reference Org. No. 2 423 100 024

01.7006.000



Full Load Screw 6 MM

01.7 040.010



Tappet Bolt
Reference Org. No. 1 413 450 010

01.7007.000



Full Load Screw 7 MM

01.7 050.025



Airvent Screw Drilled Hole Type
Thread M6 x 1
Reference Org. No. 1 413 450 025

01.7 051.000



Airvent Screw Milled Type
Thread M6 x 1
Reference Org. No. 1 413 450 002

01.7 060.000



Airvent Assy
M 12x1.5

01.7 061.000



Airvent Body
M 12 x 1.5

01.7 065.101



Airvent Assy (M14 x 1.5)
Reference Org. No. 1 413 462 101

01.7 066.000



Airvent Body
M 14x 1.5

01.7 070.000



Airvent Assy
M 16 x 1.5

01.7 071.000



Airvent Body
M 16 x 1.5

NUTS

01.8 001.000

Glaasy Nut
 Reference Org. No. 2 453 345 000

01.8 009.000

Open Nut Long Type

OD	ID	A/F Hex	Hole	Length
M16x1.5	M14x1.5	19	4	32.75

For Feed Pump 00.1901.000 & 00.1063.400

01.8 010.001
Open Nut Bosch Type

OD	ID	Hex/AF	Holes
M16x1.5	M14x1.5	19	3

Reference Org Nos. 2 443 355 001

01.8 010.100
Open Nut Zexel Type

OD	ID	Hex/AF	Holes
M16x1.5	M14x1.5	24	4

01.8 011.009
Close Nut

OD	ID	Hex/AF
M16x1.5	7	19

Reference ORG Nos. 2 443 462 009

01.8 012.014
Dog Nut

OD	ID	Hex./AF
M26x1.5	20	30

Reference ORG Nos. 2 443 462 014

01.8 013.000
Nut For 4 Valve Feed Pump

OD Thread	ID	Collar Hex/ AF
M22x1.5	M14x1.5	27

01.8 014.000
Nut For 4 Valve Feed Pump

OD Thread	ID Hex	Collar Round
M22x1.5	10	25

01.8 016.000

 Closing Plug
 M 14x1.5

01.8 017.000

 Closing Plug
 M 16x1.5

01.8 018.000
Nut With O Ring 2 x 2.5

OD Thread	ID
24x1.5	M14x1.5

Reference ORG Nos. 2 443 461 003

01.8 019.000

 Length 25
 Hole Dia 1.6
 Hex 22 A/F
 Thread M18x1.5

01.8 020.010

Tappet Nut

01.8 025.000

Cam Nut

01.8 030.000

Hex A/F	Hex Length	Bore ID	Small Bore	Step Dia	Step Length	Thread	T. Length	Oil Seal OD	Oil Seal ID	O Seal H
24	4	17.80	11.0	22	4.2	16x1.5x12	20.2	18.2	10.6	5

01.8 031.000

Hex A/F	Hex Length	Bore ID	Small Bore	Step Dia	Step Length	Thread	T. Length
24	4	17.80	11.0	22	4.2	16x1.5x12	20.2

01.8 555.000

 Adopter For
 00.9010.100
 00.9011.100

01.8 033.000

Hex A/F	Hex Length	Top ID	Hole ID	Hole Length	Thread	T. Length
26	6.30	20	10	11.50	16x1.5x7	16.50

01.8 035.0000

 M 10X1.5
 UNF 3/8" X24

01.8 037.000

Hex A/F	Hex Length	Top ID	Hole ID	Thread	T. Length
26	8	20	10	16x1.5x7	18

01.8 570.000

 OD : 10.4mm
 ID : 6.3mm
 Length : 6mm

ADAPTERS / COUPLINGS

01.8 524.140



Adopter with A.C. Valve 18mm		
OD	ID	Hex A/F
24x1.5	14x1.50	23

01.8 522.140



Adopter with A.C. Valve 18mm		
OD	ID	Hex A/F
22x1.5	14x1.50	22

01.8 520.140



Adopter		
OD	ID	Collar Round
20x1.5	14x1.50	23

01.8 522.160



Adopter		
OD	ID	Collar Round
22x1.5	16x1.50	27

CLAMPS

01.9 001.000



Clamp for Feed Pump

Reference Org. Nos. - 2 459 999 000

01.9 002.000



Clamp for Big Prefiter Assembly

KEYS & RUNNERS

01.9 101.000



Runner for Tappet Assy 'B' Type (for Inline Pump)

01.9 110.001



For Feed Pump Roller 'A' Type

Reference Part No. - 2 443 120 001, 2 443 120 007

01.9 111.008



For Feed Pump Roller 'P' Type

Reference Part No. - 2 443 120 008

COPPER WASHERS



ID	OD	TH	Part Nos	OE No.
4	8	1	02.0408.100	
4	8	1.5	02.0408.150	
5	8	1	02.0508.100	
5	9	1	02.0509.100	
5	15	2.5	02.0515.250	
5.8	10.5	1.1	02.0510.101	
6	10	1	02.0610.100	2 916 710 602 = NW5-12 007 603 006 106
6	10	1.5	02.0610.150	
6	10	2	02.0610.200	
6	11	1	02.0611.100	
6	12	1	02.0612.100	146433 0100 (Hard (VE))
6.2	15.7	2.5	02.0615.251	
6.2	13.5	2.5	02.0613.251	
6.3	12	2.5	02.0612.251	
6.5	9.5	1	02.0609.101	
6.5	12	1	02.0612.101	
7	13.8	2	02.0713.201	
7	14	4	02.0714.400	
7	14	1.5	02.0714.150	
7	14	2	02.0714.200	
7	15	1.5	02.0715.150	
7	15	1.0	02.0715.100	
7	15	2	02.0715.200	
7	14.2	1.5	02.0714.151	
7	14.2	2	02.0714.201	
7	15	2.5	02.0715.250	
7.4	15	1	02.0715.101	
7.4	15	1.5	02.0715.151	
7.4	15	2	02.0715.201	
7.4	15	2.5	02.0715.251	
7.5	13	2.5	02.0713.251	
7.5	15.7	1.5	02.0715.151	
7.5	17	2	02.0717.201	
7.5	17	2.5	02.0717.251	
8	11	1	02.0811.100	146600 0400
8	11	1.5	02.0811.150	
8	11.5	1	02.0811.151	007 603 008 109
8	12	1	02.0812.100	2 916 710 608
8	12	1.5	02.0812.150	2 916 710 603 S
8	12.5	1	02.0812.101	
8	13.5	1	02.0813.101	
8	14	1	02.0814.100	
8	14	1.5	02.0814.150	
8	16	0.5	02.0816.050	
8	15	2	02.0815.200	
8.4	11.25	1	02.0811.101	
9	14	1	02.0914.100	
9	18	1	02.0918.100	
9	19	2	02.0919.200	
9	20	1	02.0920.100	
9	20.5	1	02.0920.101	
9	21	1.7	02.0921.170	
9	22.5	1	02.0922.101	
9.3	13.8	1	02.0913.101	

OTHER SIZES ARE ALSO AVAILABLE ON ORDER

COPPER WASHERS



ID	OD	TH	Part Nos	OE No.
10	13	1.5	02.1013.150	
10	14	1	02.1014.100	
10	14	1.5	02.1014.150	
10	14	2	02.1014.200	
10	15	1.5	02.1015.150	
10	16	4	02.1016.400	
10	16	1	02.1016.100	
10	18	2	02.1018.200	
10	18.5	1.5	02.1018.151	
10	18.5	2	02.1018.201	
10	19	1	02.1019.100	
10	19	1.5	02.1019.150	
10	20	1.5	02.1020.150	
10	20	2.5	02.1020.250	
10	20	1	02.1020.100	
10	20	2	02.1020.200	
10	21	2	02.1021.200	
10	22	1	02.1022.100	
11	16	1.5	02.1116.150	
11	16	2	02.1116.200	
11	17	1	02.1117.100	
11	18	1.5	02.1118.150	
11	18	2	02.1118.200	
11	19.5	1	02.1119.101	
12	16	1	02.1216.100	
12	16	1.5	02.1216.150	2 916 710 607
12	17	1.5	02.1217.150	
12	18	0.5	02.1218.050	
12	18	1.5	02.1218.150	2 916 710 608
12	18	2.5	02.1218.250	
12	18.5	2	02.1218.201	
12	19.5	1	02.1219.101	
12	15.5	1.5	02.1215.151	
12	22	1	02.1222.100	
12	28.5	1.5	02.1228.151	
13	17	1	02.1317.100	
13	19	1	02.1319.100	
13	19	1.5	02.1319.150	
14	17	0.20	02.1417.020	
14	17	1.5	02.1417.150	
14	18	1	02.1418.100	2 916 710 609
14	18	1.5	02.1418.150	
14	20	1	02.1420.100	
14	20	1.5	02.1420.150	2 916 710 610
14	20	2	02.1420.200	
14	22	1.4	02.1422.140	9 431 610 274 150623 420
14.5	21	1.5	02.1421.151	
14.5	21	2	02.1421.200	
15	20	3	02.1520.300	
15	21.5	3	02.1521.301	
15.5	21	2	02.1521.201	
15.5	20.5	2	02.1520.201	
15.5	21	2.5	02.1521.251	
15.5	21.5	2	02.1521.201	
16	19	1	02.1619.100	
16	19.5	1	02.1619.101	1 230 203 001
16	19.5	1.5	02.1619.151	
16	20	1.5	02.1620.150	2 916 710 611
16	22	1.5	02.1622.150	2 916 710 611 S

OTHER SIZES ARE ALSO AVAILABLE ON ORDER

COPPER WASHERS



ID	OD	TH	Part Nos	OE No.
16	20	1	02.1620.100	
16.5	24.5	2	02.1624.201	
17	20	1.5	02.1720.150	
17	21	1.5	02.1721.150	
17	21	1.5	02.1721.150	
17.5	31.5	1.5	02.1731.151	
17.5	22.5	3	02.1722.301	
18	21.4	1.5	02.1821.151	
18	22	1	02.1822.100	768043
18	22	1.5	02.1822.150	2 916 710 613
18	24	1.5	02.1824.150	
18	24	2	02.1824.200	
20	23	2	02.2023.200	15936-188 H Cav 10140 W Simms Cav
20	24	1	02.2024.100	
20	24	1.5	02.2024.150	
20	26	1.5	02.2026.150	
20	24	1.5	02.2024.150	
21	25	0.8	02.2125.080	
21	25	1	02.2125.100	
21	25	1.5	02.2125.150	
21	25.5	0.8	02.2125.081	
21	26	1.5	02.2126.150	2 916 710 633
22	26	0.8	02.2226.080	
22	26	1	02.2226.100	
22	26	1.5	02.2226.150	
22	27	1.5	02.2227.150	
22	28	1.5	02.2228.150	
22	29	1.5	02.2229.150	
24	29	2	02.2429.200	
24	30	2	02.2430.200	
24	32	2	02.2432.200	
24	40	1.5	02.2440.150	
24	34	2	02.2434.200	
25	40	1.5	02.2540.150	
26	24	2	02.2624.200	
26	30	1	02.2630.100	2 440 105 000, 2 916 710 619
26	32	2	02.2632.200	
26	34	2	02.2634.200	
26.5	41	1	02.2641.101	
27	32	2	02.2732.200	
28	33	2	02.2833.200	
28	34	2	02.2834.200	
28	36	2	02.2836.200	
30	36	2	02.3036.200	
30	38	2	02.3038.200	
32	38	2	02.3238.200	
33	39	2	02.3339.200	
33	41	2	02.3341.200	
35	41	2	02.3541.200	
36	42	2	02.3642.200	
38	44	2	02.3844.200	
38	46	2	02.3846.200	
40	47	2	02.4047.200	
42	48	2	02.4248.200	
42	49	2	02.4249.200	
45	52	2	02.4552.200	
61.5	75	1.5	02.6175.151	
77	92	1.5	02.7792.150	
78	111	1.5		
100	126	1		

OTHER SIZES ARE ALSO AVAILABLE ON ORDER

STRAIGHT PIPES

06.0001.000

F.I. Pipe 100 cm A & B Nut

06.0002.000

F.I. Pipe 100 cm B & B Nut

06.0003.000

F.I. Pipe 24" A & B Nut

06.0004.000

F.I. Pipe 24" B & B Nut

06.0005.000

F.I. Pipe 32" A & B Nut

06.0006.000

F.I. Pipe 32" B & B Nut

06.0007.000

F.I. Pipe 84 cm B & B Nut

06.0008.000

F.I. Pipe 32" A & A Nut

06.0009.000

F.I. Pipe 100 cm A & A Nut

06.0011.000

F.I. Pipe 120 cm A & B Nut

06.0012.000

F.I. Pipe 90 cm A & B Nut

06.0015.000

F.I. Pipe 120 cm A & A Nut

06.0016.000

F.I. Pipe 90 cm A & B Nut

06.6017.000

F.I. PIPE 50cm B & B Nut

06.6018.000

F.I. PIPE 50cm A & B NUT

06.6019.000

F.I. PIPE 60cm A & A NUT

06.6020.000

F.I. PIPE 60cm B & B NUT

06.6021.000

F.I. PIPE 60cm A & B NUT

06.6022.000

F.I. PIPE 65cm A & A NUT

06.6023.000

F.I. PIPE 65cm B & B NUT

06.6024.000

F.I. PIPE 65cm A & B NUT

06.6025.000

F.I. PIPE 70cm A & A NUT

06.6026.000

F.I. PIPE 70cm B & B NUT

06.6027.000

F.I. PIPE 70cm A & B NUT

06.6028.000

F.I. PIPE 70cm A & A NUT

06.6029.000

F.I. PIPE 75cm B & B NUT

06.6030.000

F.I. PIPE 75cm A & B NUT

06.6031.000

F.I. PIPE 78cm A & A NUT

06.6032.000

F.I. PIPE 78cm B & B NUT

06.6033.000

F.I. PIPE 78cm A & B NUT

06.6034.000

F.I. PIPE 80cm A & A NUT

06.6035.000

F.I. PIPE 80cm B & B NUT

06.6036.000

F.I. PIPE 80cm A & B NUT

06.6037.000

F.I. PIPE 85cm A & A NUT

06.6038.000

F.I. PIPE 85cm B & B NUT

06.6039.000

F.I. PIPE 85cm A & B NUT

06.6040.000

F.I. PIPE 90cm B & B NUT

06.6041.000

F.I. PIPE 105cm A & A NUT

06.6042.000

F.I. PIPE 105cm B & B NUT

06.6043.000

F.I. PIPE 105cm A & B NUT



FUEL INJECTION PIPES

06.0314.000



Ref. No. 314 070 1333



Ref. No. 314 070 1433



Ref. No. 314 070 1533



Ref. No. 314 070 1633

Application : Merc. 314

06. 0352.000



Ref. No. 352 070 3233



Ref. No. 352 070 3333



Ref. No. 352 070 3433



Ref. No. 352 070 3533



Ref. No. 352 070 3633

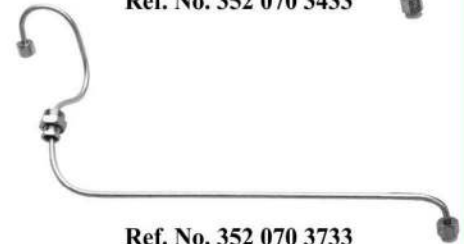

Ref. No. 352 070 3733

Application : Merc. 352

06.0355.000

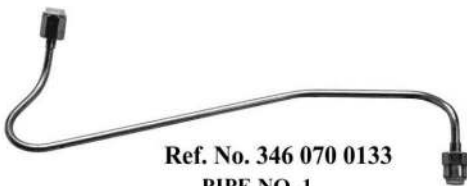

Ref. No. 346 070 0133
PIPE NO. 1



Ref. No. 346 070 0433
PIPE NO. 4



Ref. No. 346 070 0333
PIPE NO. 3

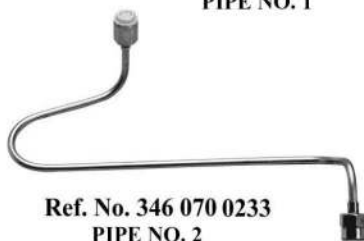

Ref. No. 346 070 0233
PIPE NO. 2

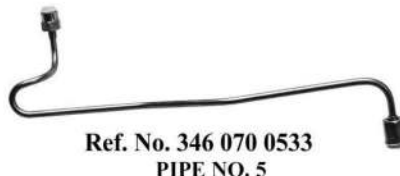

Ref. No. 346 070 0533
PIPE NO. 5

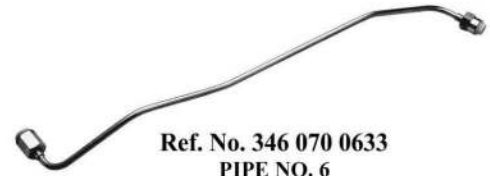

Ref. No. 346 070 0633
PIPE NO. 6

Application : Merc. 355 (Old Model)

FUEL INJECTION PIPES

06.0355.A00



Ref. No. 355 070 0333



Ref. No. 355 070 0433



Ref. No. 355 070 0533



Ref. No. 355 070 0633



Ref. No. 355 070 0733



Ref. No. 355 070 0833

Application : Merc. 355 A (New Model)

06.0366.000



Application : Merc. OM 366

06.0403.000

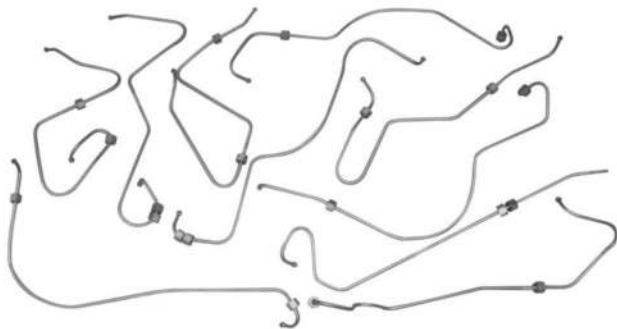

Application : Merc. 403

06.0403C.000

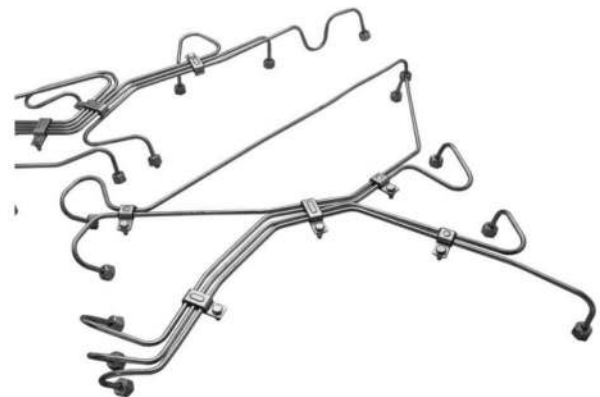

Application : Merc. 403, CLAMPED

FUEL INJECTION PIPES

06.0441.000

Ref. No. : 441 070 1133



Ref. No. : 441 070 6733

Application : Merc. 441

06.0402C.000



**Reference Part No.
422 070 5433**

**Reference Part No.
422 070 8433**

APPLICATION : Merc 402, CLAMPED

06.0442.000

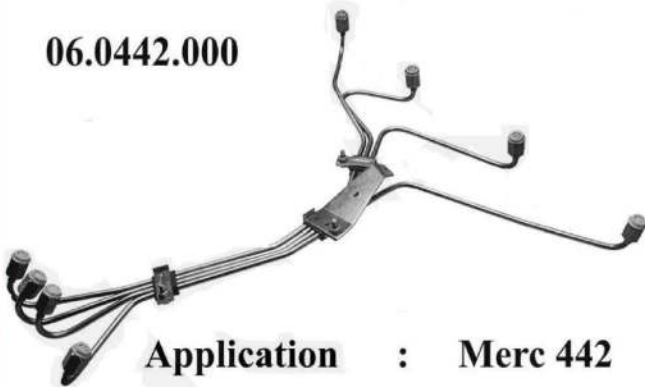

Application : Merc 442
Reference Part No.
Mercedes : 442 070 9633

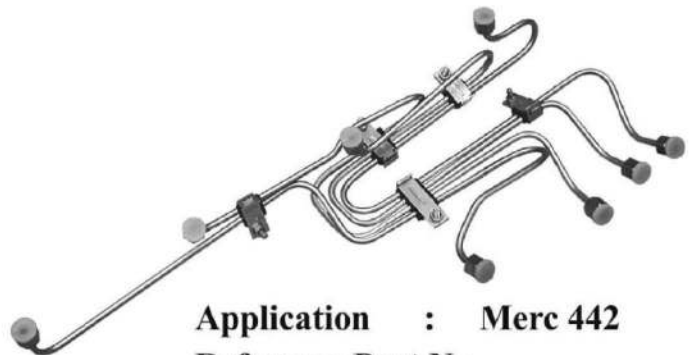

Application : Merc 442
Reference Part No.
Mercedes : 442 070 8133

06.1333.000



Ref. no. : 442 070 1333

06.1433.000



Ref. no. : 442 070 1433

FUEL INJECTION PIPES

06.1033.000



Cylinder Head Pipe

Application : OM355/355A

Reference Part No.

Mercedes : 346 070 1033

06.1034.000



06.1040.000



Reference Part Org. Nos. :

906 070 1433

Application : Merc. Atego

06.1933.000



Application : Merc

Reference Part No.

Mercedes : 541 070 1933

06.7635.000



Cylinder Head Pipe

Application : OM355/355A

Reference Part No.

Mercedes : 345 070 7635

FUEL INJECTION PIPES

06.0407.002



Application : TATA 407 T

06.0407RT.002

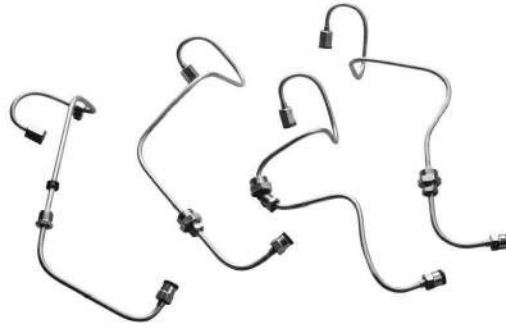

Application : TATA 407 RT

06.1210.002



Application : TATA 1210 SE

06.1612.002



Ref. Mico No. F 002 H20 500-079

Application : TATA 1612

FUEL INJECTION PIPES

06.1612 .002



06.1613 R.002

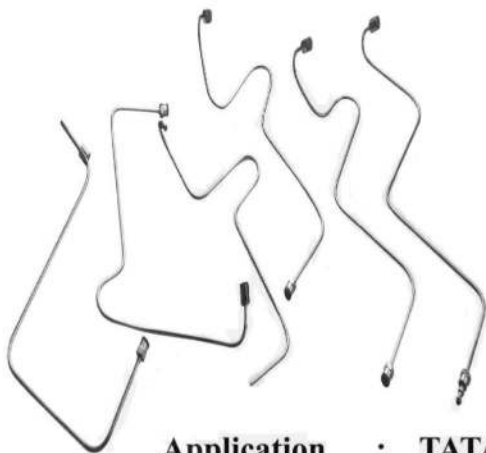

Application : TATA 1613

06.1613 RT.002

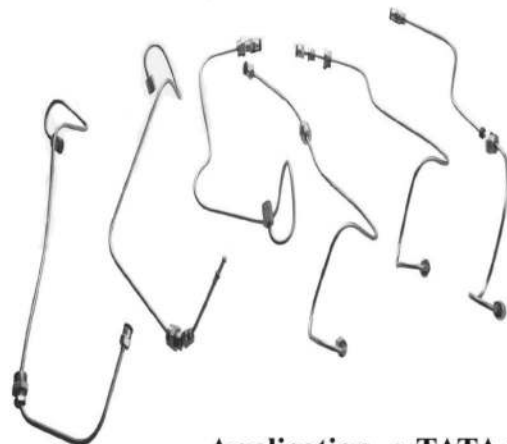

Application : TATA 1613 RT

06.0100.002



TATA ACE

06.0709RT.002



TATA 709
ROTARY TURBO

FUEL INJECTION PIPES

06.2416 TC.002

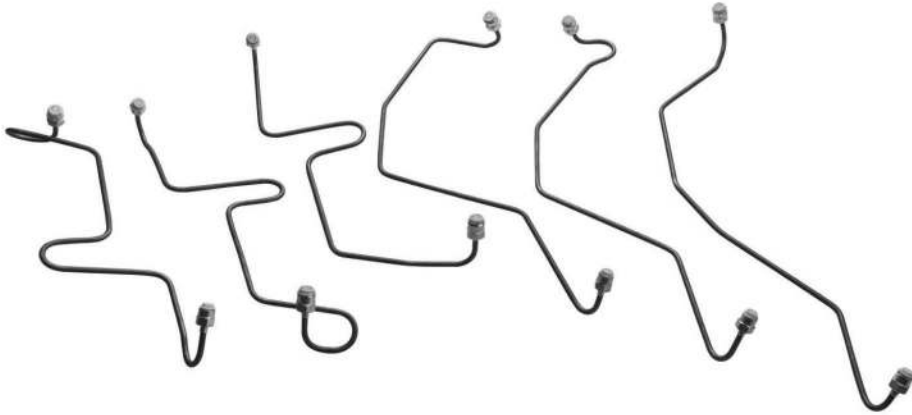

Application : TATA 2416 TC

06.2516.002



**Application : TATA 2516
/ 4018 / 3516 / 2518**

06.0511.010

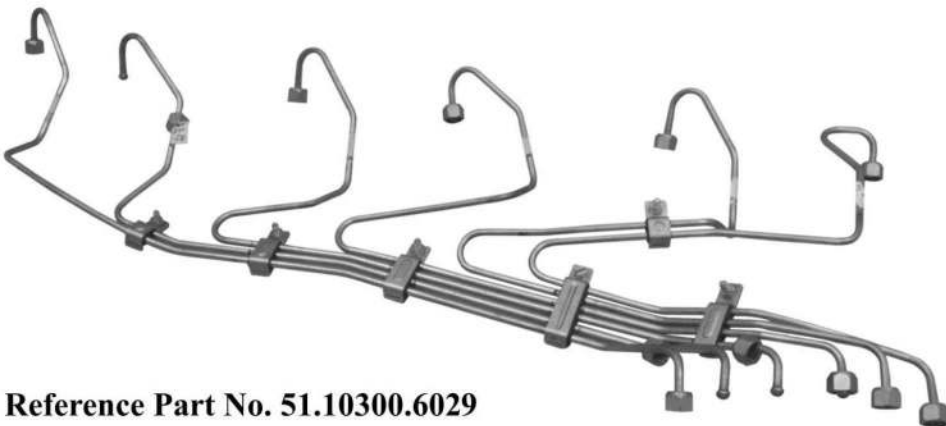

**Reference Part No. 51.10300.6029
51.10303.6129
51.10302.6198**

Application : MAN 511

FUEL INJECTION PIPES

06.2000.010



Application : MAN 2000

06.2156.010

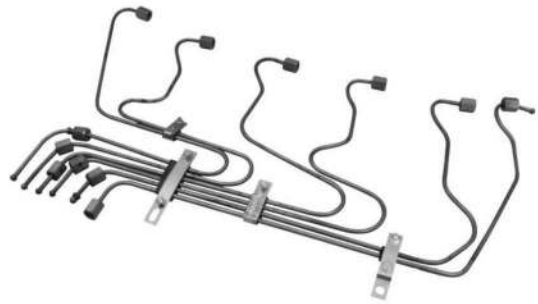

Application : MAN D 2156 MT6

06.2866.010

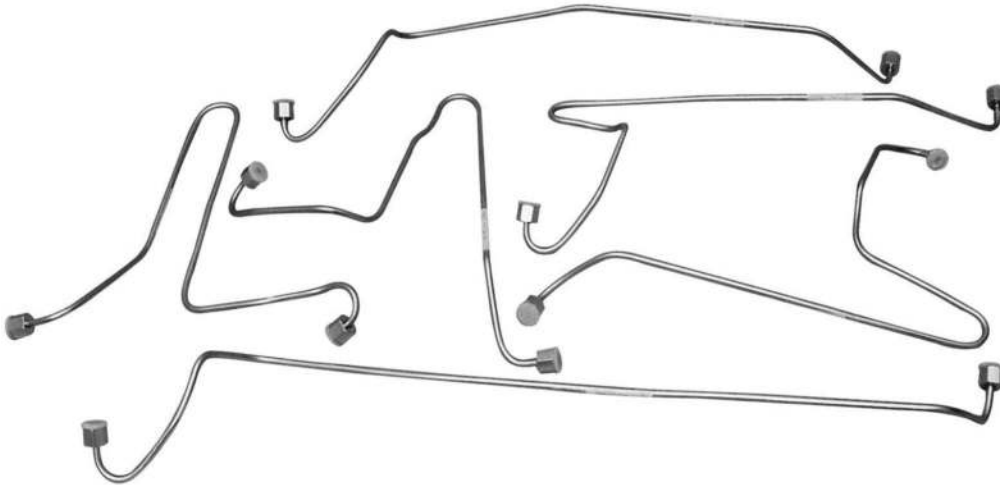

Application : MAN 2866 Unclamped

06.6032.010



Application : MAN 51.10300.6032

06.6023.010



Application : MAN 51.10300.6023

FUEL INJECTION PIPES

06.0100.011

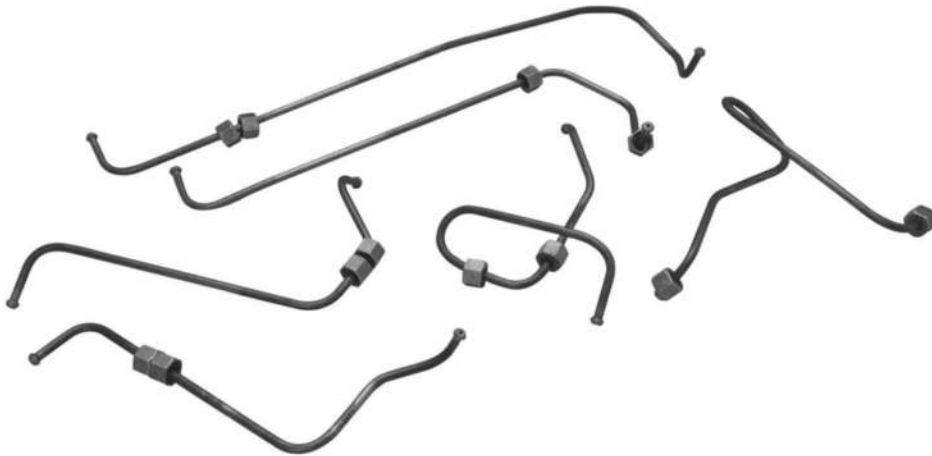

Application : Volvo TD - 100

06.0120.011



Application : Volvo L-120 (IR)

06.0121.011

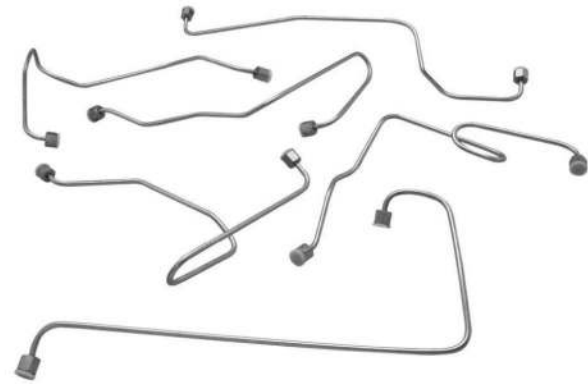

Application : Volvo TD 120

Chevy / GMC / Ford / Dodge / Duramax Pipes



FUEL INJECTION PIPES

06.0122.011



Application : Volvo TD - 122

06.1000.011



Application : Volvo

06.1010.011

24427317

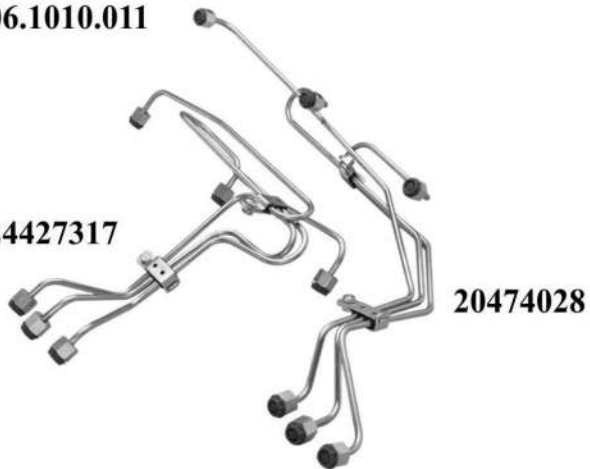

20474028

**Application : Volvo N-10 New Model
TD - 100 G**

06.1011.011



Application : Volvo N-10 Old Model

FUEL INJECTION PIPES

06.1012.011

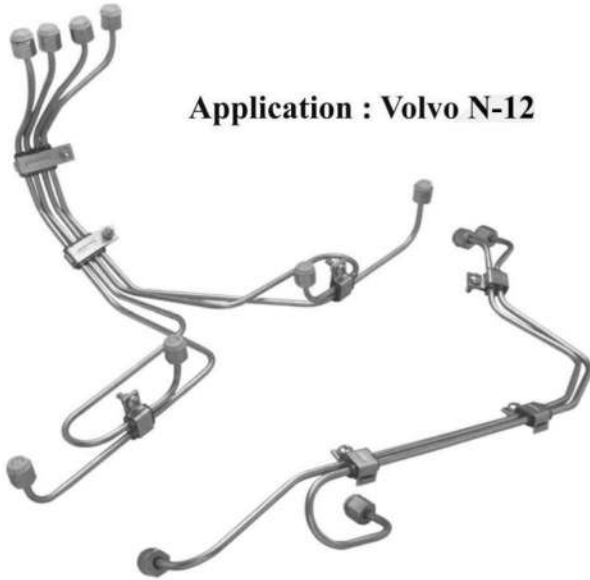

Application : Volvo N-12

06.0060.011

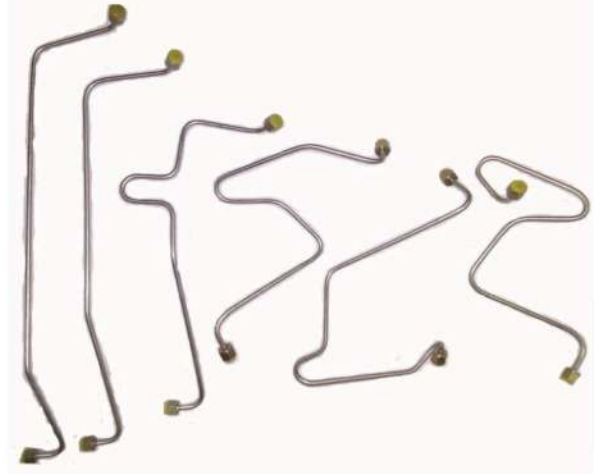

Application : Volvo TD-60

06.4400.011

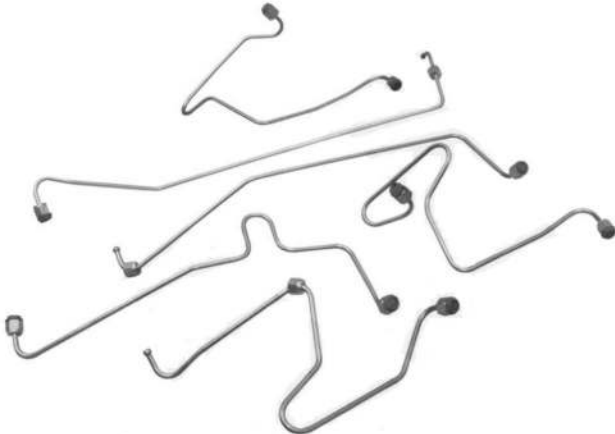

Application : Volvo 4400

06.0070.011



Application : Volvo TD-70

06.4500.011

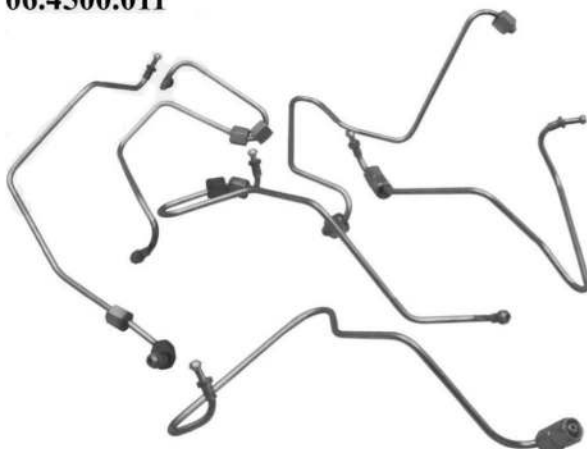

Application : Volvo 4500

FUEL INJECTION PIPES

06.0011.012



Application : SCANIA - DS11

06.0093.012



Application : SCANIA 093

06.0111.012

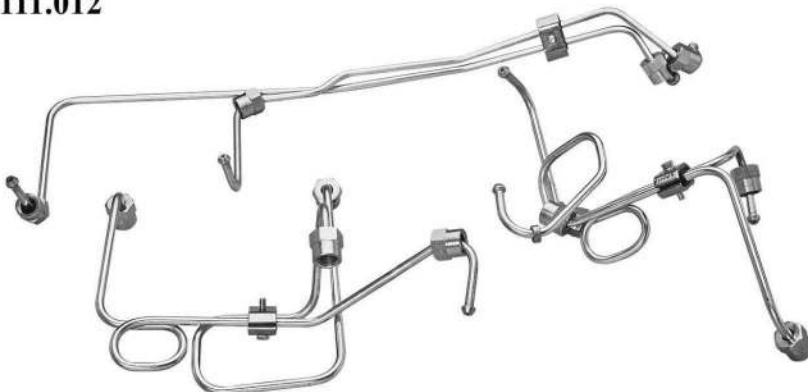

Application : SCANIA 111 6 CYL

FUEL INJECTION PIPES

06.0112.012

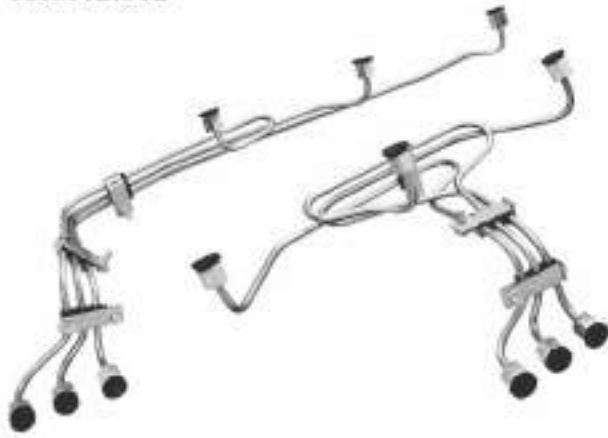

Application : SCANIA112

06.0113.012 06.0113A.012

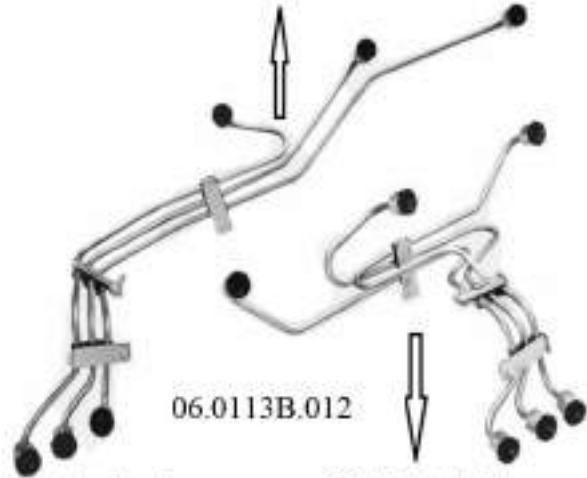

Application : SCANIA 113

06.0124.012



Application : SCANIA124

06.0146.012

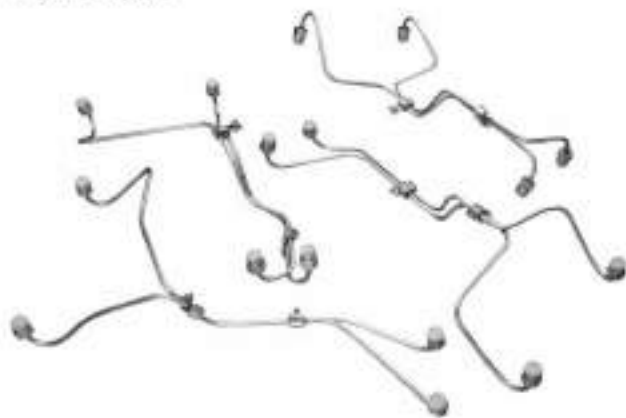

Application : SCANIA 146 (DS14)

06. DSCP. 012



Application : SCANIADSCP

FUEL INJECTION PIPES

06.1300.013



Application : IVECO

06.1903.013

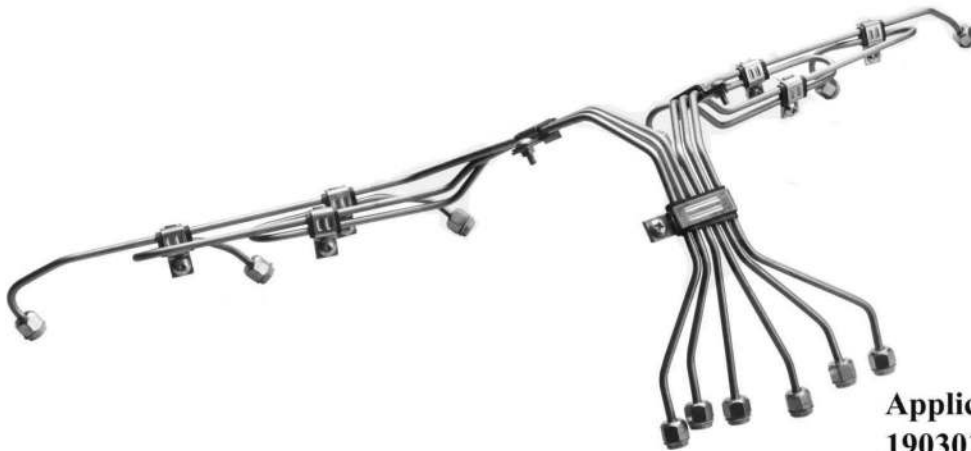

Application : IVECO
1903019030
330 MODEL 475610 - 4815735

06.9124.014

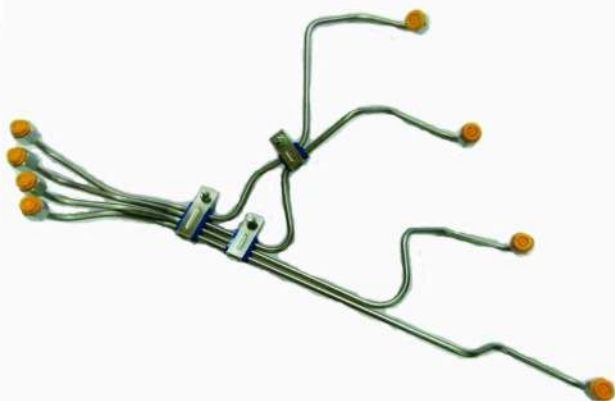

Application : DEUTZ 912(4 Cylinder)

06.9126.014

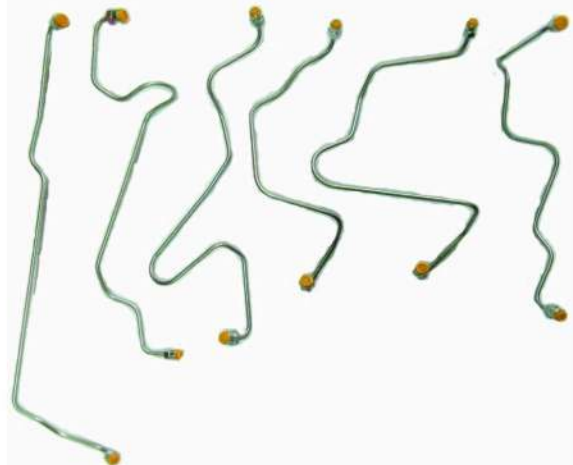

Application : DEUTZ 912(6 Cylinder)

FUEL INJECTION PIPES

06.0504.019



Application : PEUGEOT-504,
Set of 4 Pc with Clamps

06.0505.019



Application : Peugeot 504 New Model

06.4236.020



Application : Perkins 4.236

06.0290.020



Application : MF 290

06.1000.020

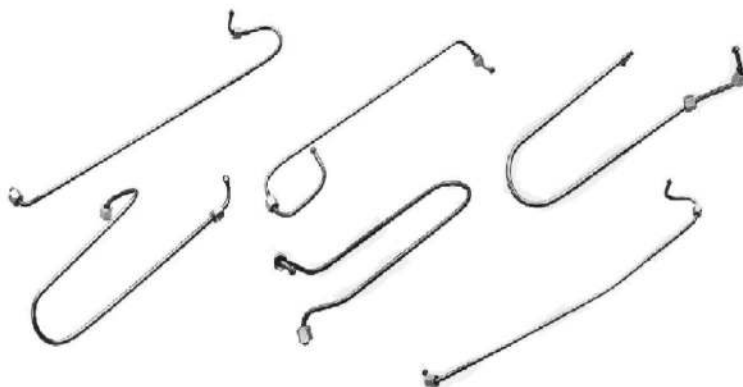

Application : Perkins P6

FUEL INJECTION PIPES

06.4000.021



Application : Ford 4000

06.6610.021



Application : Ford 6610

06.6600.021



Ref. No. 81814454



Ref. No. 83924090



Ref. No. 81814457



Ref. No. D9 NN9A 555 DA

06.6600.021/454

06.6600.021/090

06.6600.021/457

06.6600.021/555 DA



Ref. No. D9 NN9A 558 CA



Ref. No. D9 NN9A 556 DA



Ref. No. 81814453



Ref. No. 81814458

06.6600.021/558 CA

06.6600.021/556 DA

06.6600.021/453

06.6600.021/458

Application : Ford 6600

06.1003.022

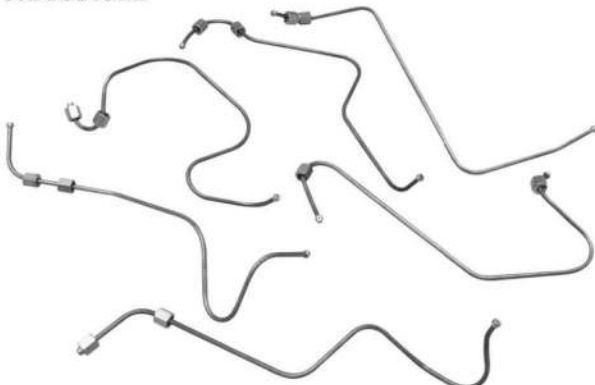

Application : Bed Ford J6

06.0001.023

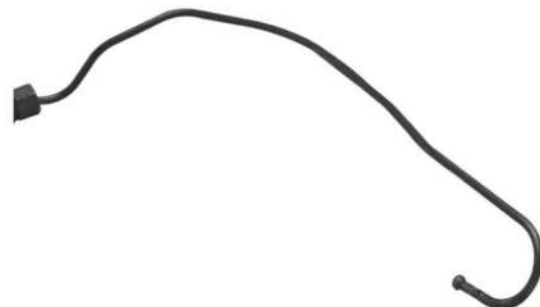

**Application : Ruston Engine 1 Cylinder,
2 Cylinder and 3 Cylinder**

FUEL INJECTION PIPES

06.1000.024



Application : Fordson

06. 8204. 025



**Application : FIAT
440 E 47 MAT. 42M PUMPA 'P'**

06. 0040.025



Application : FIAT 40

06.3304.030

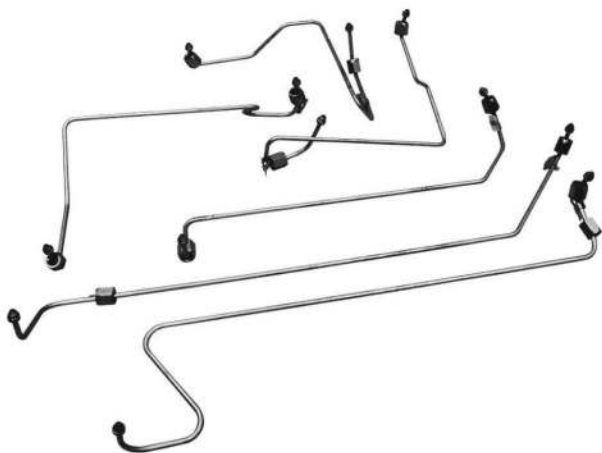

Application : Cater Pillar 3304

06.3406.030



Application : Cater Pillar 3406

FUEL INJECTION PIPES

Application : Caterpillar

06.7941.030



Ref. Part No. 191-7941

06.7942.030



Ref. Part No. 191-7942

06.7943.030



Ref. Part No. 191-7943

06.7944.030



Ref. Part No. 191-7944

06.7945.030



Ref. Part No. 191-7945

06.7946.030

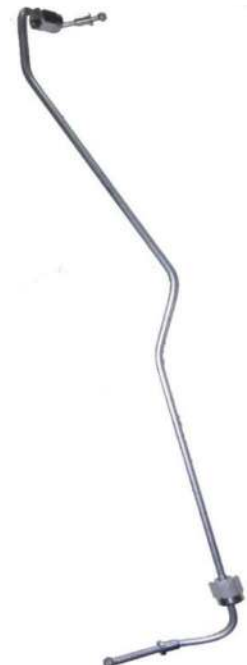

Ref. Part No. 191-7946

FUEL INJECTION PIPES

06.04BT.031

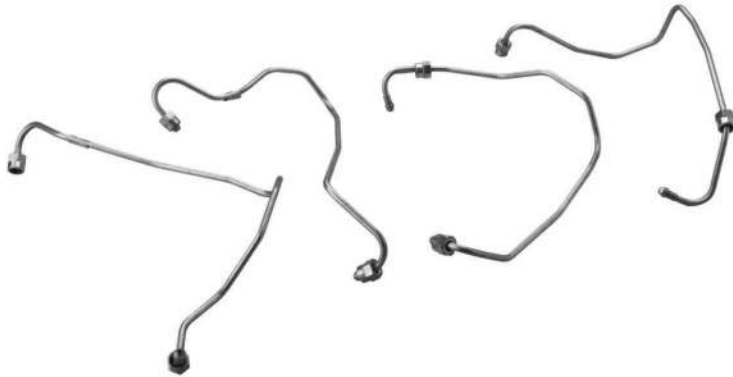

Application : CUMMINS 4BT

06.3368.031

Reference Part No. : 3 66 33 68
Application : Cummins



06.6190.031

Reference Part No. : 3 02 61 90
Application : Cummins



06.6189.031

Reference Part No. : 3 02 61 89
Application : Cummins



06.6842.031

Reference Part No. : 3 96 68 42
Application : Cummins



06.7780.031



Reference Part No. : 3 91 77 80
Application : Cummins

06.6BTI.031

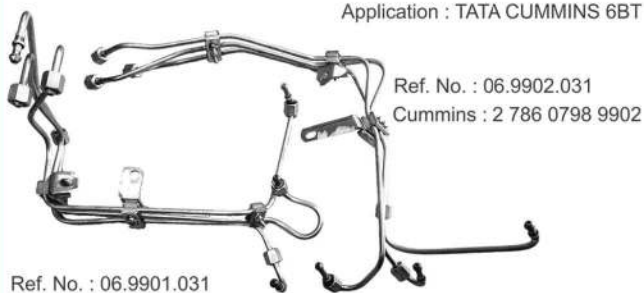

Ref. No. : 06.9901.031
Cummins : 2 786 0798 9901

Application : TATA CUMMINS 6BT

Ref. No. : 06.9902.031
Cummins : 2 786 0798 9902

06.6BTR.031



Application : TATA CUMMINS 6BT

FUEL INJECTION PIPES

06.0122.035



Application : Mitsubishi (6D22)

06.0100.036



Application : Hitachi - EX100

06.0200.036



Application : Hitachi - EX200

FUEL INJECTION PIPES

06.0421.037



Application : KOMASTU
421.09.11320

06.6151.037

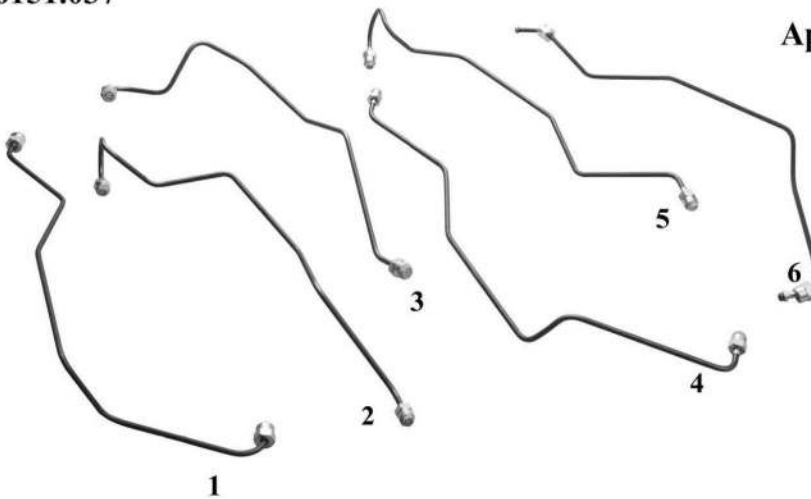

Application : KOMASTU

1. 6151 - 71 - 5110
2. 6151 - 71 - 5120
3. 6151 - 71 - 5131
4. 6151 - 71 - 5140
5. 6151 - 71 - 5150
6. 6151 - 71 - 5160

06.6156.037

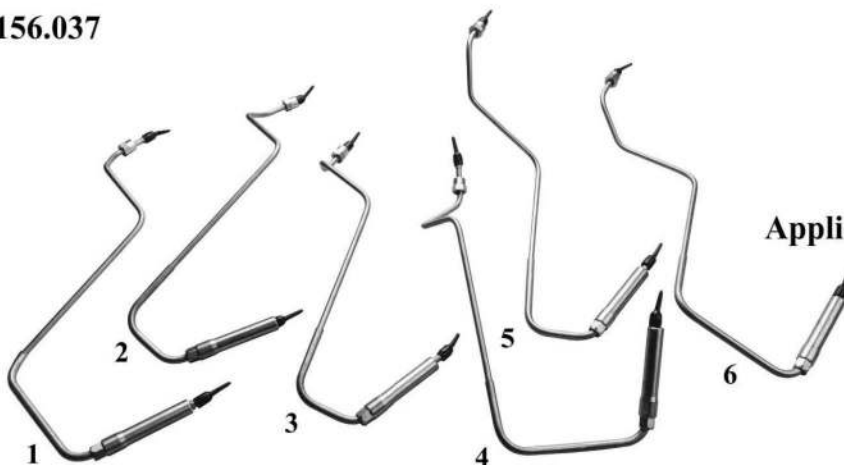

Application : KOMASTU

1. 6156 - 71 - 5111
2. 6156 - 71 - 5122
3. 6156 - 71 - 5132
4. 6156 - 71 - 5141
5. 6156 - 71 - 5152
6. 6156 - 71 - 5161

FUEL INJECTION PIPES

06.6211.037

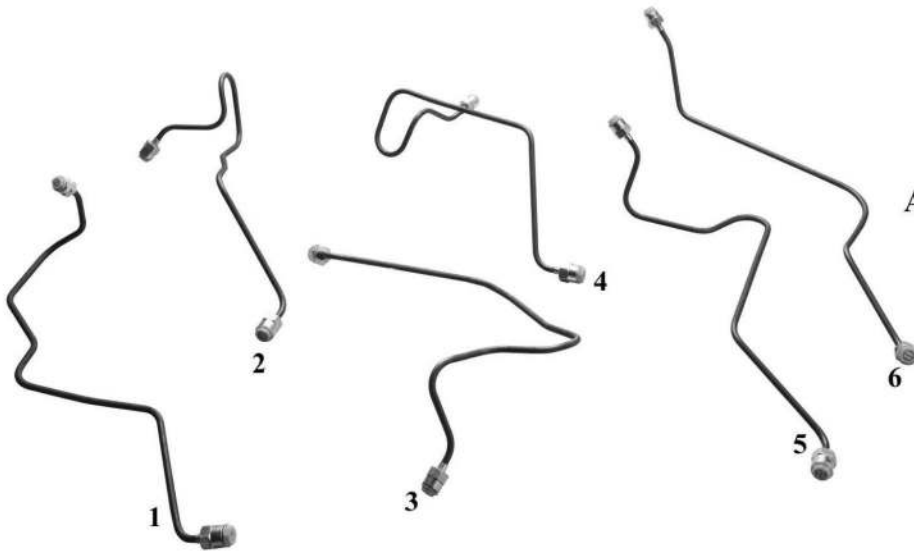

Application : KOMASTU

1. 6211 - 71 - 5110
2. 6211 - 71 - 5120
3. 6211 - 71 - 5130
4. 6211 - 71 - 5140
5. 6211 - 71 - 5150
6. 6211 - 71 - 5160

06.6217.037

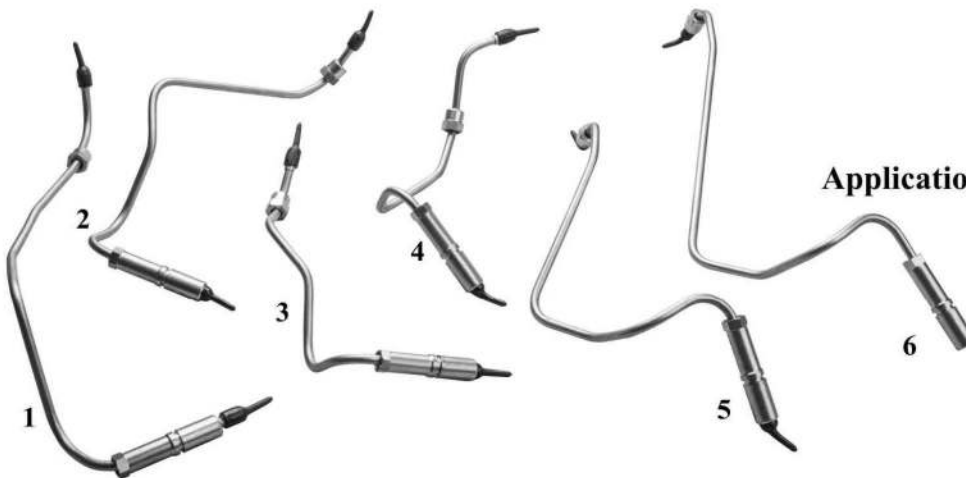

Application : KOMASTU

1. 6217 - 71 - 5112
2. 6217 - 71 - 5122
3. 6217 - 71 - 5132
4. 6217 - 71 - 5142
5. 6217 - 71 - 5152
6. 6217 - 71 - 5162

06.6221.037

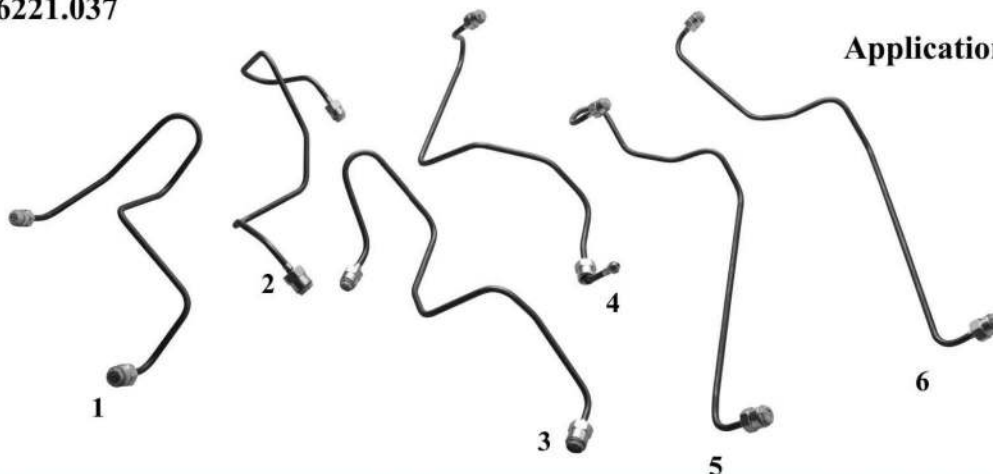

Application : KOMASTU

1. 6221 - 71 - 5111
2. 6221 - 71 - 5121
3. 6221 - 71 - 5131
4. 6221 - 71 - 5141
5. 6221 - 71 - 5150
6. 6221 - 71 - 5160

FUEL INJECTION PIPES

06.6232.037

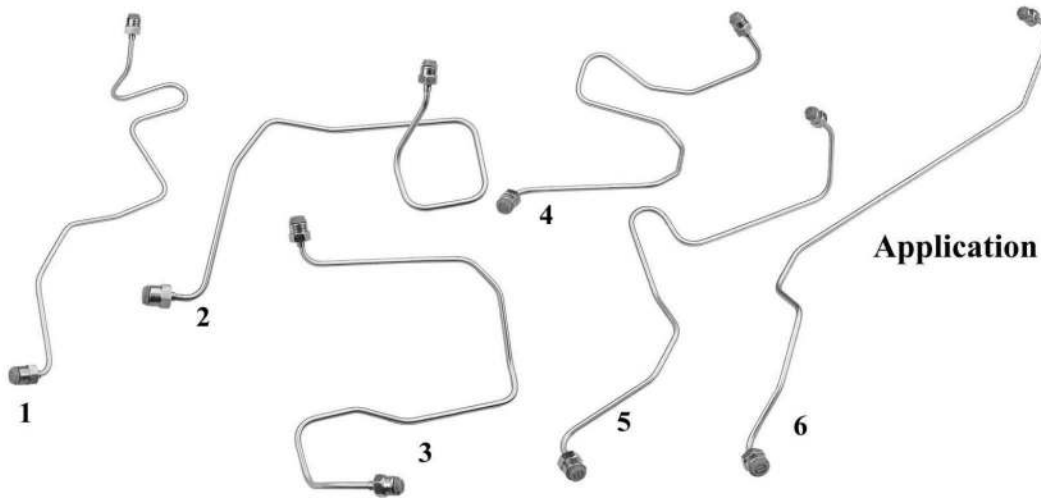

Application : KOMASTU

1. 6232 - 75 - 1111
2. 6232 - 75 - 1112
3. 6232 - 75 - 1113
4. 6232 - 75 - 1114
5. 6232 - 75 - 1115
6. 6232 - 75 - 1116

06.6242.037

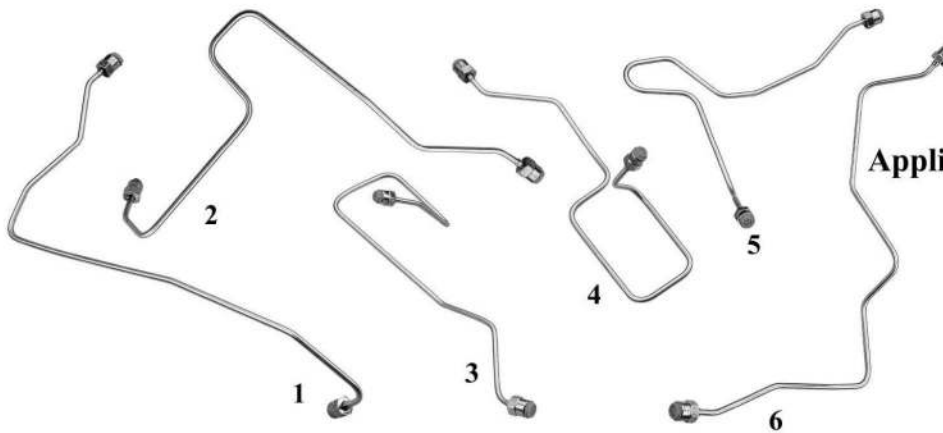

Application : KOMASTU

1. 6242 - 75 - 1111
2. 6242 - 75 - 1112
3. 6242 - 75 - 1113
4. 6242 - 75 - 1114
5. 6242 - 75 - 1115
6. 6242 - 75 - 1116

FUEL INJECTION PIPES

06.6735.037

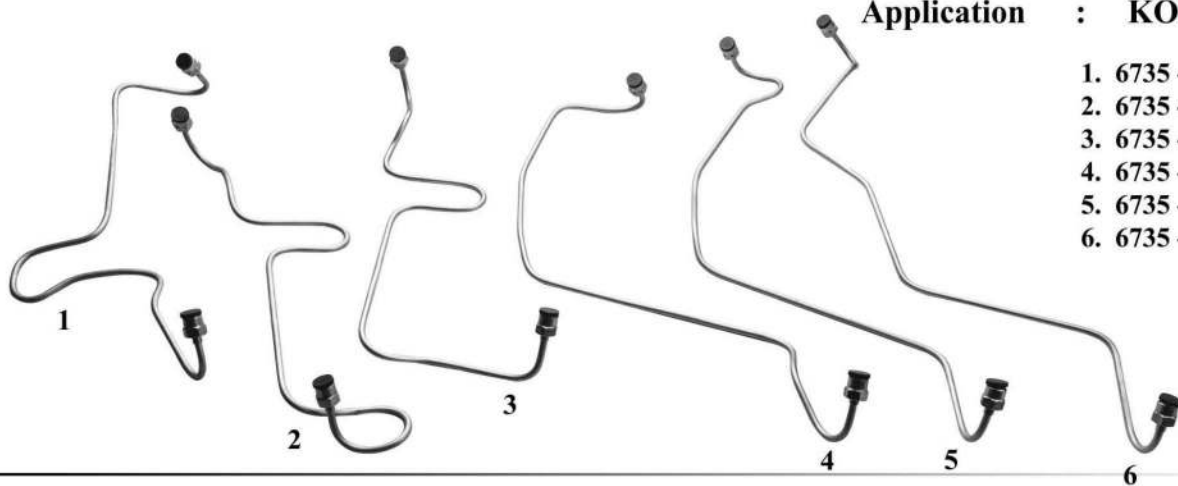

Application : KOMASTU

1. 6735 - 71 - 5614
2. 6735 - 71 - 5623
3. 6735 - 71 - 5633
4. 6735 - 71 - 5643
5. 6735 - 71 - 5653
6. 6735 - 75 - 5663

06.SDIT.038



Application : Isuzu 65 ZDIT (Turbo)

06.DMAX.038

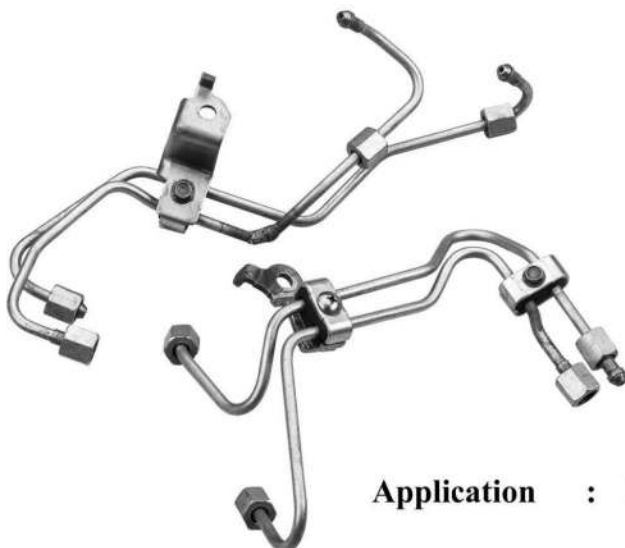

**Application : Isuzu D:MAX PICKUP
Set of 4 pcs with big clamp**

Application : Isuzu 65 ZDIT (Turbo)

FUEL INJECTION PIPES

06.1 007.039 (Old No. 06.1007.099)

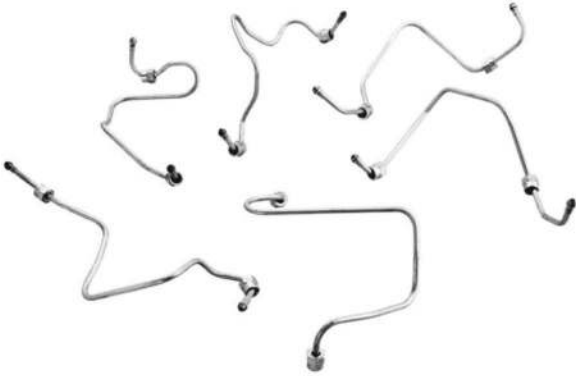

Application : Hino HO7D

06.1008.039 (Old No.: 06.1008.099)



S 2370 - 11740



S 2370 - 31580



S 2370 - 61430

Application : HINO J08C

06.1 011.039 (Old No. ; 06.1 011.099)

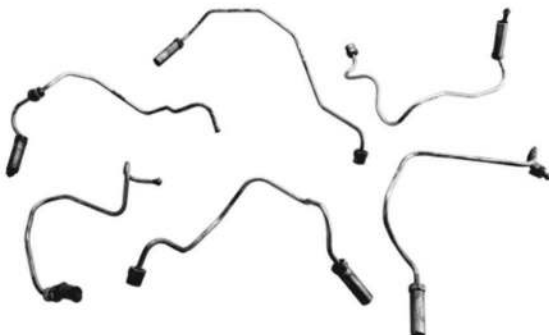

Application : Hino P11C

FUEL INJECTION PIPES

06.8439.040 (Old No. 06.8439.095)

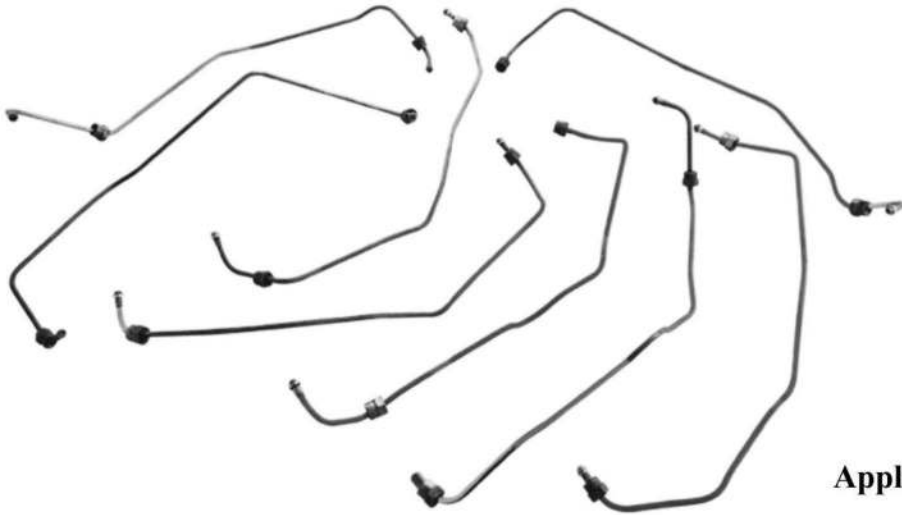

Application : Fuso 8DC9

06.0370.050 (Old No. 06.0370.100)



Application : LEYLAND 370

06.0401.050 (Old No. 06.0401.100)



Application : LEYLAND 401

CONNECTING ROD

MERCEDES BENZ

- 1 OM 314 OLD MODEL / OM - 352
- 2 OM 366 STRAIGHT (366 030 2520, 366 030 3520, 366 030 2120 / 7120) OM - 314 NEW MODEL AND ALSO TATA 1612
- 3 OM 366 TAPPER (366 030 3620, 366 030 7320)
- 4 OM 352 (352 030 5720, 352 030 4920, 352 030 3920)
- 5 OM 355 NEW MODEL (355 030 2820, 355 030 2120, 355 030 1920)
- 6 OM 355 OLD MODEL (355 030 0020)
- 7 OM 447 STRAIGHT (447 030 0420)
- 8 OM 447 TAPPER (447 030 0320, 466 030 0320)
- 9 OM 403 / OM - 422 (442 030 0420, 422 030 0320, 403 030 1720)
- 10 OM 442 TAPPER (442 030 0220, 442 030 0020)
- 11 OM 360 (360 030 0120)
- 12 OM 441 (441 030 0820)
- 13 OM 407 (407 030 0620)
- 14 OM 457 (457 030 0120)
- 15 OM 601 / 602 SPRINTER {601 030 4720 / 4420}
- 16 SPRINTER {646 030 0020} TAPPER
- 17 OM 501 {541 030 0520 / 0320 / 0420} 6 CYL FRACTURE TYPE
- 18 OM 502 {542 030 0520 / 0320 / 0420} FRACTURE TYPE
- 19 OM 906 {906 030 1220 / 0320} 8 CYL (42MM PIN) FRACTURE TYPE
- 20 OM 904 {904 030 0220} (40MM PIN) FRACTURE TYPE



VOLVO

- 1 VOLVO TD 120, TD - 121, TD - 122, TD - 123 - 470424
- 2 VOLVO TD 100 1545299
- 3 N 12 OLD MODEL TD - 120
- 4 TD 100 N - 12 (422706) OLD MODEL
- 5 VOLVO D 12 (204 12200)
- 6 VOLVO FH 12 (FRACTURE TYPE) 534 204 12200

SCANIA

- 1 SCANIA DS 11 (WITH OIL HOLE) 1305643
- 2 SCANIA DS 11 (WITHOUT OIL HOLE) 1403521
- 3 DS 12 (1401729)

MAN

- 1 D 0824 (51.02401.6277 / 6221) FRACTURE TYPE
- 2 D 2876 LF - LOF - LOF01 (51.024000.6049) D - 2866 - (LOF) FRACTURED
- 3 D 2866 (51.02400.6044)
- 4 D 0834 / 0836 (51.02400.6023 / 6263 / 6268)

DEUTZ

- 1 DEUTZ FL 912 (0415 0450)
- 2 DEUTZ FL 912 (ASTRIN) (0337 1614) 40.00MM
- 3 DEUTZ FL 913 C (0415 0455)
- 4 DEUTZ 614 (MEGIRUS) (0335 8847)
- 5 DEUTZ 413 (0414 3222)
- 6 DEUTZ FL 913 (0415 - 2302 / 0223 2059)
- 7 DEUTZ 511 (0415 1493)

CUMMINS

- 1 CUMMINS 6 - BT (3901569 / 3942551)
- 2 CUMMINS 6 - CT(3901383)
- 3 CUMMINS NT - 855 (3013930)
- 4 KT - 1150
- 5 6BT FRACTURE TYPE (3939405)

COMPRESSOR

- 1 352 130 0216 (97mm)
- 2 352 130 0416 (92mm)
- 3 403 130 2816 / 2216 (20mm Thickness)
- 4 403 130 2716 (16mm Thickness)
- 5 ATALS COPCO VT - 4
- 6 442 131 0017 / 0217, 541, 131 0117
- 7 ATLAS COPCO VT - 5

CONNECTING ROD

CATERPILLAR

- 1 CATERPILLAR 6N 8011 TAPPER (BIG THICKNESS)
- 2 CATERPILLAR 9N 0406 / 1W2558 TAPER
CATERPILLAR 8N - 1720 TAPER (SMALL),
(PIN : 38 : 10MM)
- 3 CATERPILLAR 8N - 1726 TAPER (BIG)
(PIN : 43 : 18MM / TAPPER)
- 4 CATERPILLAR 8N - 1727 (2P933 - 2 - EMV - RND)
(PIN : 43 : 18MM / STRAIGHT)
- 5 9Y 6048 (55 MM PIN)
- 6 9Y (50.80 MM PIN)

LEYLAND

- 1 LEYLAND 370 / 400
- 2 LEYLAND 402 / 411
- 3 LEYLAND 680

HINO

- 1 H 07 C 046 - 00147
- 2 H 700 A 128 - 400 - 337
- 3 H 800 128 - 400 - 338

TOYOTA

- 1 F J80 RN (9204) 13201 - 35020
- 2 BU85.BB 13201 - 59057
- 3 3 - L 13201 - 59105
- 4 ACV10.120
- 5 SXV10.20.ST 191 13201 - 59105
- 6 4 K
- 7 3 K
- 8 C - 240
- 9 12 R
- 10 2 - L (QUALIS)
- 11 14B.3B.BB2 (13101 - 58040) RENO
- 12 TOYOTA 1Z
- 13 TOYOTA 1DZ

MITSUBISHI

- 1 MITSUBISHI 4D - 31 / CENTER ME012264
- 2 MITSUBISHI 4D - 34 / FE 012265
- 3 4D56 / 4D55 / T - 120 MO 050006 (L - 300 diesel)
- 4 FUSO
- 5 RANGER
- 6 6d34 Inter Coller
- 7 I - 300 Petrol
- 8 L - 038



KOMATSU

- 1 KOMATSU L - 95 (6207 / 06) (S6D95L)
- 2 KOMATSU L - 120 (6138 - 31 - 3101)
(S6D110) (SA6D110)
- 3 KOMATSU W - 90 (6150 V) (S6D125)
(6150 - 31 - 3101)
- 4 6151 - 31 - 3101 (S6125) TAPPER
- 5 KOMATSU W - 120 (6127 B) (S6D155)
(6127 - 31 - 3101 / 3100)
- 6 KOMATSU (6136 - 31 - 3100)
- 7 KOMATSU (6136 - 32 - 31111)

DIAHATSU

- 1 DG (V - 26) 13201 - 87304 - DG (26mm)
- 2 DL (V - 22) 13201 - 87309 - DL (28mm)
- 3 HIJET (13201 - 87107)
- 4 CHARADE

PERKINS - GENERATORS

- 1 KP - 73025

CONNECTING ROD

TRACTORS (PERKINS / MF)

- 1 P3 / P4 / P6 (ZZ-90011) 3637439M91 / 4.192
- 2 MF - 135
- 3 MF - 245 (ZZ-90010) (P3.152, P4.203) (ZZ-90010) 3637392M91
- 4 P6.354 ROCKET (ZZ-90009) (P4.248, P4.236, P4.212) 3637034M91
- 5 P6.354 TURBO ROCKET (ZZ-90013) 367028M91 Phaser 1004.40
- 6 P6.354 TURBO ROCKET PIN TYPE (ZZ-90058) Phaser1006.60
- 7 TURBO FRACTURE TYPE

TRACTORS (FIAT)

- FIAT 32MM (450 / 480 / 640) 50 NC EM (67 - 77) (4775229)
- FIAT 34MM (780 54C 640 50 NC YM 77) (4798181)
- FIAT 38MM (PEMO TURBO) 35.9 65.9 (4780624)
- FIAT 38MM TAPPER (98460411)

TRACTORS (JOHNDEERE)

- 1 Re58347 JOHNDEERE 41.275 MM PIN
- 2 RE505454 32mm (501072) Fracture Type R80034 / RE 21076 / TRE16495 / R51727 (34.95mm PIN) ER55978
- 3 R26047 (640) (38mm PIN) AR70910, R58880
- 4 R71074 (643) (47mm PIN) Taper / 4000 Series 4250 to 4955 AR93341,67320
- 5 T20007, EAT 18005, R81410 (30.195 mm PIN)
- 6 R41423 / R58882 Straight (41MM)ER 70912
- 7 AR55978 JOHNDEERE 30.195MM PIN
- 8 Re505454 32mm (501072) Fracture Type
- 9 R500335 / R114081 (642) Fracture Type (41mmPIN) Taper RE 500608
- 10 R500000 / Re123959 (644) FractureType (35mm PIN) RE 50002

FORD

- FORD 3000 / 3600 (C7NN6200A)
- FORD 9000 (C9NN6200C)

ROMANIA

- ROMANIA UTB - 650 (UTB 10303015)



TRACTORS (HMT)

- 1 HINDUSTAN - 50 (WITH DOEWL PIN AND NOTCH)
- 2 HINDUSTAN - 80

STEYR

- 1 STEYR - 768 (4070030012)

URSUS

- 1 ESCORTS - 335 / URSUS C-330 (2 - CYL.) S312C (42032100)

ZETOR

- 1 ZETOR : 2011 / 3011 / 4011 / 2V / 3V (46503230)
- 2 GTCL TRACTOR (ZETOR WITH COUNTER WEIGHT) (71010309)
- 3 ZETOR - Heavy Cross Type / Ursus 385 / Engi. No. Z8401 (89003529)

PEUGEOT

- 1 PEUGEOT : 504.505
- 2 PEUGEOT : 405.205 - 1800cc
- 3 PEUGEOT : 2000c
- 4 PEUGEOT : 206 (18MM)
- 5 PEUGEOT : 206 (1600cc) 19.460MM

CONNECTING ROD

PETTER

- 1 PETTER PH - 1(CROSS TYPE) 30MM
(1W - 350254)
- 2 LISTER ST - 1

CON ROD KIRLOSKAR (MWM)

- 1 MWM - 229
- 2 MWM - 10 / 562

LANDROVER

- 1 LANDROVER
- 2 MAXION 2.5 HS (TAPER)
- 3 HRC 1385 SDF 57 (WITH NYLON NUT)
(GROOVE TYPE)
- 4 LANDROVER HRC 1385

ANDORIA

- 1 ANDORIA S - 320

BEDFORD

- 1 BEDFORD J4 / J6

KIA

- 1 PRIDE

WHEELER (LOMBARDINI)

- 1 LOMBARDINI 450 / 510
- 2 LOMBARDINI 520

PAYKAN

- 1 AVENGER
- 2 DELUXE LONG



YANMAR

- 1 ST - 1
- 2 TS - 50
- 3 TS - 60
- 4 TS - 105
- 5 TS - 180 / TS - 155
- 6 TF - 65
- 7 TS - 70
- 8 KIND - 180 / SD - 004 / ER - 100
- 9 TS - 230
- 10 2T
- 11 E - 8

Infrastructure



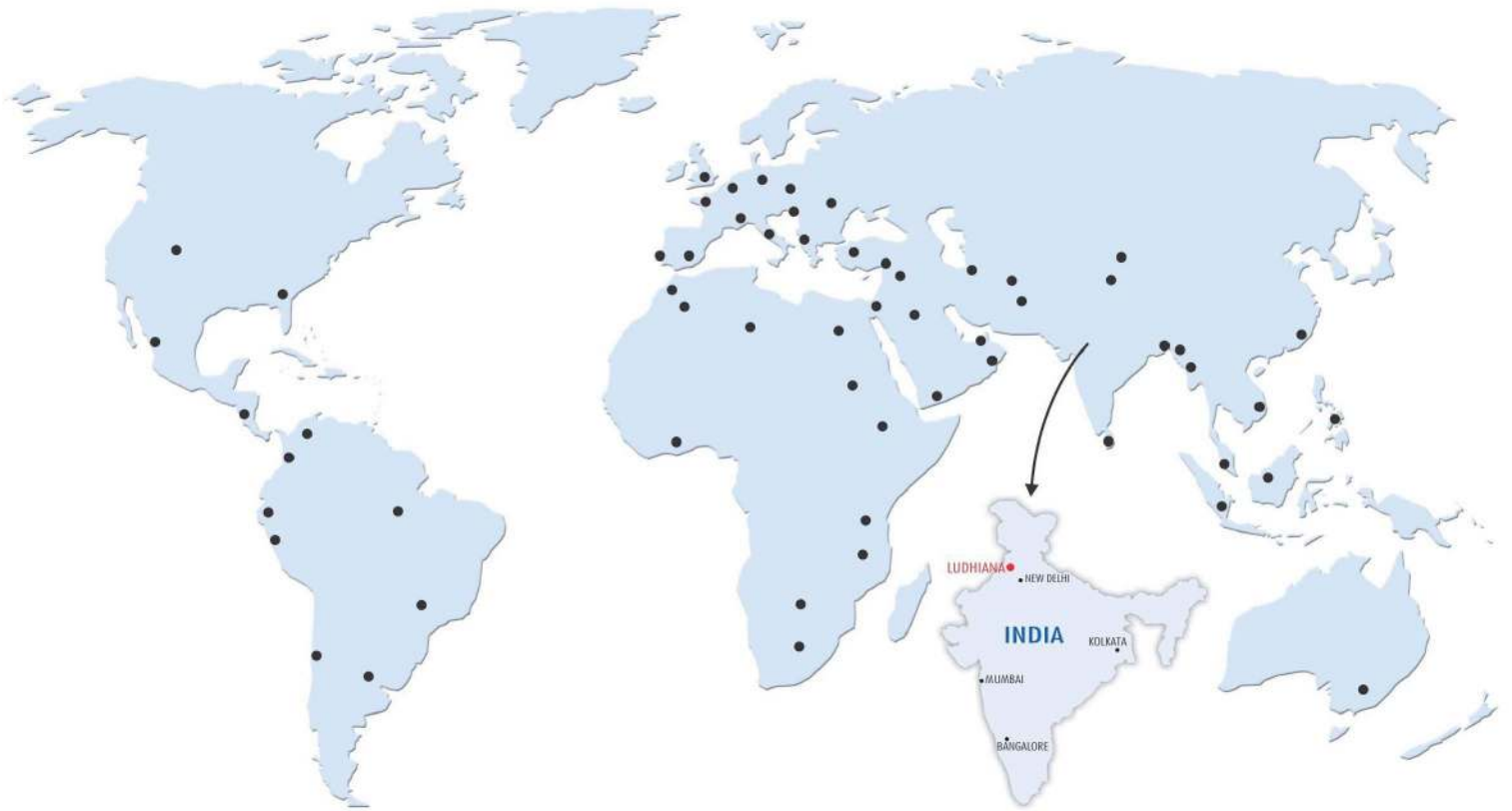

www.rajnishinternational.com

Manufacturer & Exporter

Rajnish INDUSTRIES PVT. LTD

E-26, Phase - IV, Focal Point, Ludhiana - 141 010 (INDIA)

Tel. : + 91 - 161 - 2670324, 2671033 Fax : + 91 - 161 - 2674590, 5043601

E-mail : rajnishinternational1@gmail.com info@rajnishinternational.com